

Performance Analysis of Buried Natural Gas Pipeline under Uneven Settlement Action

Shijie Wang^a, Yanhua Chen^b, Haibin Chen, Zhenying Zhang

School of Civil Engineering, North China University of Science and Technology, Tangshan
063210, China

^a2105414456@qq.com, ^bcyh427@163.com

Abstract

This paper uses ABAQUS software, considering the nonlinear contact of pipe soil and buried soil material, and studies the simulation experiment of X100 steel pipe under uneven settlement conditions. The influence of settlement, internal pressure and wall thickness on the strain of steel pipe are discussed. The results show that compared with the internal pressure, the wall thickness has a greater impact on the deformation, the increased wall thickness can effectively reduce the maximum pressure strain, and the maximum pressure strain position will move to the axial direction. Deformation analysis and prevention of X100 steel pipe under uneven settlement conditions are very important, which will play a positive role in improving the safety and reliability of the pipeline and avoiding potential safety accidents.

Keywords

Natural Gas Pipeline; Uneven Settlement; Finite Element Analysis.

1. Introduction

Natural gas is not only safe, reliable, economical, but also environmentally friendly. It is one of the cleanest fossil energy sources and is widely used at home and abroad. The main long-distance transportation mode of natural gas is buried pipeline transportation. By 2021, the total laying of natural gas pipelines in China has reached 92,000 km [1]. There are many safety problems faced by buried pipelines in the process of transportation, and uneven settlement, as one of them, seriously threatens the safe use of gas pipelines. As a part of the 14th Five-Year Plan [2], it is necessary to prevent serious accidents such as leakage, stress analysis and failure analysis of operating pipelines under the action of uneven settlement.

Some scholars at home and abroad have made a digital simulation of [3] for the pipeline under the settlement state. In 2004, Yimsiri [4] et al. constructed a model of the pipeline buried in two kinds of soil, and controlled the lateral and vertical motion of the soil for finite element analysis. In 2010, LiuChunguang [5] used ANSYS to establish a three-dimensional model of pipeline floating in the case of soil liquefaction, and used a soil spring model for nonlinear contact of pipe soil to analyze the stress change characteristics of pressure during the floating displacement of buried pipelines in the liquefaction area. In 2011, [6] established the 3 d model of buried pipe under the action of soil subsidence, with discrete entity unit simulation soil, analyzed the subsidence area length, pipe properties, site conditions on the buckling deformation and the deformation characteristics of buried pipe, in 2012, Popov A B. [7] using finite element software to establish a fan pipe elbow model, analyzed the stress and strain characteristics of the model, and get the maximum effect force of fan elbow. H.G.Kunert [8] By establishing a finite element 3 D model of the buried pipeline, the stress state of the soil movement is studied. By controlling the soil displacement, analyzing the process of pipeline reaching failure, which provides the basis for pipeline failure research. Balkaya et al [9]

established a finite element model for the uneven settlement of the soil at different positions of the pipe, analyzed the mechanical characteristics of different positions of the pipe during the soil settlement, and found that the vertical strain of the soil at the bottom of the joint is greater than other positions of the pipe. In 2014, Wu Shaoyan [10] et al. used FLAC3D finite element software to establish a 3 D model of pipeline buried in soil with different depth thickness ratios and different loose layer thickness, and simulated and analyzed the pipeline. The maximum tensile stress of the pipeline in the goaf is located at the edge of the settlement area, and the stress at the bottom of the subsidence basin is mainly manifested as the compressive stress. At the edge and center of the basin, the buried pipeline is the most prone to damage, and the axial stress of the buried pipeline has a linear relationship with the loose thickness of the soil. Li Yukun et al. [11] used ANSYS software to establish a three-dimensional model of the pipeline under the uneven settlement condition of the reclaimed soft soil foundation. The equivalent soil spring model was used to simulate the pipe and soil interaction. This paper mainly analyzes the stress and strain changes of the pipeline. In 2015, Zhang Yinan et al. [12] used the finite element method to establish a three-dimensional model of the pipeline under the action of settled soil, and analyzed the influence of the inclined pipe section Angle on the deformation of the pipe crossing structure, and found that the Angle of the inclined pipe section 50 across the structural pipe section is the most stable. In 2017, Shen-Zhu Zhang [13, 14] et al. studied the distribution and maximum stress strain under ABAQUS finite element model and combined with actual cases.

In 2022, Liu Wei et al. [15] established a 3-D model of steel pipe, PE pipe, ductile iron and ash cast iron pipe in the case of uneven settlement to study the impact of pipeline parameters on deformation and failure. When the ground settlement is large, the pipeline will have large strain or large radial deformation, resulting in buckling failure or failure of ellipticity failure. When the settlement is small, the strain of the pipeline is also small, and the pipeline does not fail, but the reliability of the pipeline will be reduced. In 2023, Ma Xiaoming [16] verified the validity of the measured pipeline stress data and the feasibility of ABAQUS finite element model by analyzing the actual value of stress monitoring and numerical simulation results of the pipeline under uneven settlement. And through numerical simulation to change the pipeline parameters and soil parameters to study the mechanical properties of the pipeline.

The above scholars have done a lot of research on the stress analysis of pipelines under uneven settlement, most of which focus on the stress distribution of pipelines, the maximum Mises stress and the influence of pipeline parameters on stress, but less strain analysis under uneven settlement. Because of the uneven settlement of pipeline leakage and fracture, it is likely that explosion and combustion events will endanger the safety of citizens' life and property. Based on the finite element software ABAQUS and the transverse circular rod tensile test data of X100 pipeline, the nonlinear contact of pipe soil and the influence of gas pipeline parameters and soil settling parameters on pipeline strain stress and the deformation analysis under different operating pressure. This paper provides a reference for the protection and construction of pipelines under uneven settlement.

2. Establishment of the Finite Element Model

2.1. Material Properties and Parameters

In this paper, the measured data of X100 steel pipe is selected [17], and the pipe diameter is 762mm, the wall thickness is 14mm, the elastic modulus $E = 210$ GPa, Poisson ratio $\gamma = 0.4$. The measured stress and strain curve is shown in Fig.1.

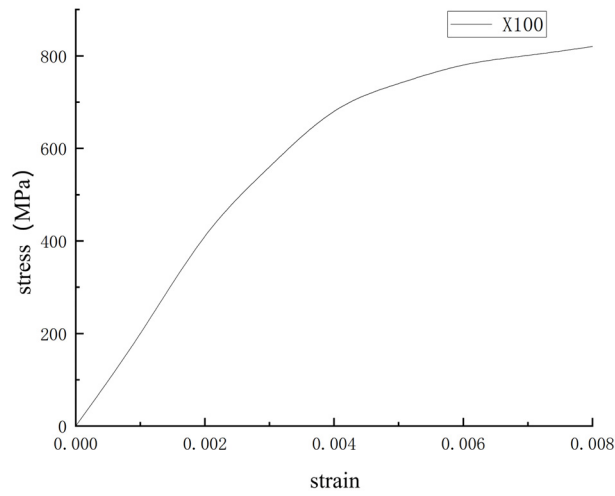

Fig 1. Stress and strain curve of X 100 steel

According to the downward offset distance of the uneven settled soil measured by Zheng et al. [18,19]

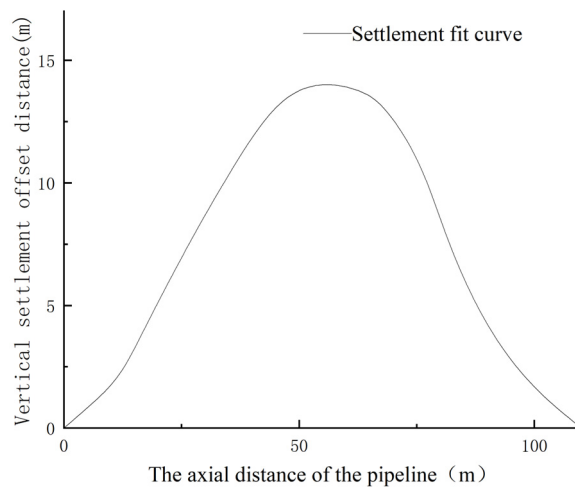

Fig 2. The measured uneven fitting curve

For large deformation of pipe under uneven settlement, use Ramberg-Osgood model, and the stress and strain relationship are shown in Expression 1. Then, the Drucker-Prager model is selected for the soil constitutive relationship, which is more suitable for the case of large deformation of the pipeline, and the Mohr-Coulomb model obtains the Drucker-Prager model after the modification of the stress yield criterion. The soil elastic modulus is 33 MPa, a density of 1 900 kg/m³, a cohesion of 28 kPa and a friction angle of 36.

$$\varepsilon = \frac{\sigma_0}{E} \left[1 + \frac{\alpha}{1+\nu} \left(\frac{\sigma_0}{\sigma_s} \right) \right]^\nu \tag{1}$$

Settlement test, generally assume: the settlement area as a whole, the pipeline is a long natural gas direct pipe, ignoring the corrosion and defects of the pipeline, the same materials of the

pipe backfill model. For settlement, in order to make the number module more accurate, the fourth settlement distribution curve is used to establish the analytical field make corrections.

$$h = a * pow(\frac{(30000 - z)}{1000}, 4) + b * pow(\frac{(30000 - z)}{1000}, 2) + c \tag{2}$$

2.2. Model Building

The model soil adopts 60m ×10m ×8m to reduce the influence of calculation length, and the buried depth is 2m. Abaqus There are three ways of contact, surface contact, point surface contact, little contact, pipe soil contact choice to use surface contact, pipe surface is rigid surface, and the soil surface is flexible surface. When settlement occurs, the pipe and soil displacement together, the whole process is nonlinear, and the friction of pipe and soil is 0.3. Boundary condition setting: the upper surface of the model is the ground surface, without constraint; the right half is the settling area for the X-axis and z-axis direction, and see Fig.3 and Fig.4 for the model.

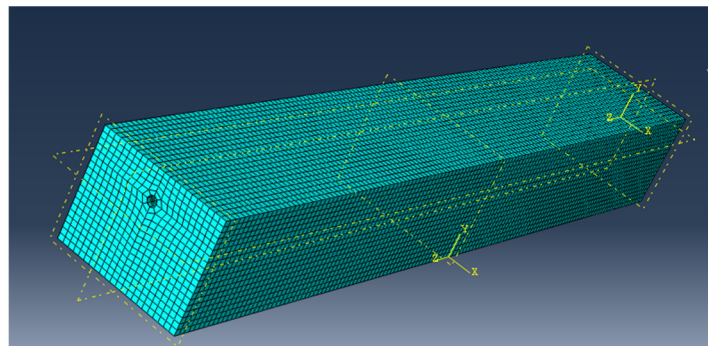

Fig 3. Model meshing diagram

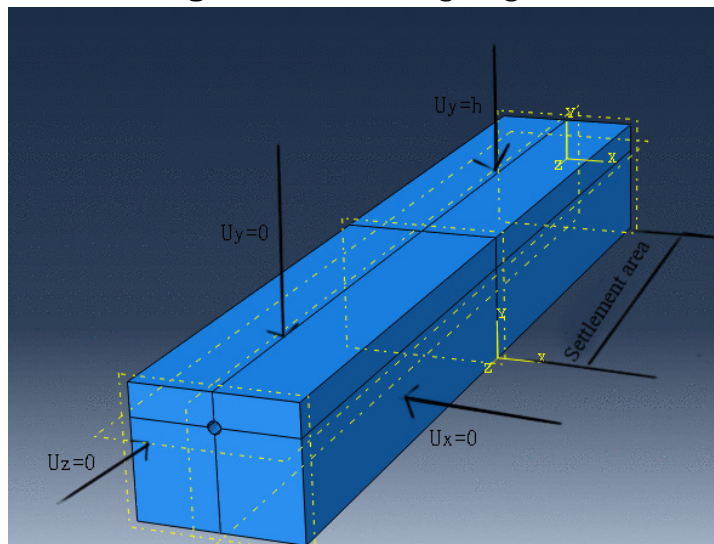

Fig 4. Constraint imposed on model

3. Results Analysis

3.1. Effect of the Pipe Internal Pressure

According to the standard, the maximum internal pressure is 8 MPa. In the other cases, the pipeline was divided into four conditions: 1MPa, 4 MPa, 6 MPa and 8MPa, to study the influence of internal pressure on the gas pipelines. Fig.5 shows the regular curve of the change of the maximum axial compressive strain of the pipeline when the maximum settlement is 500mm under the analytical field. Fig.6 shows the change of the axial position of the maximum compressive strain with the settlement.

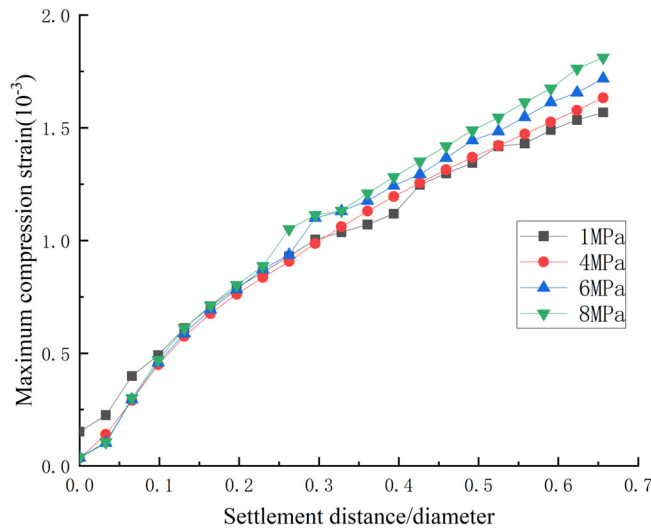

Fig 5. Maximum axial compressive strain curve under different internal pressures

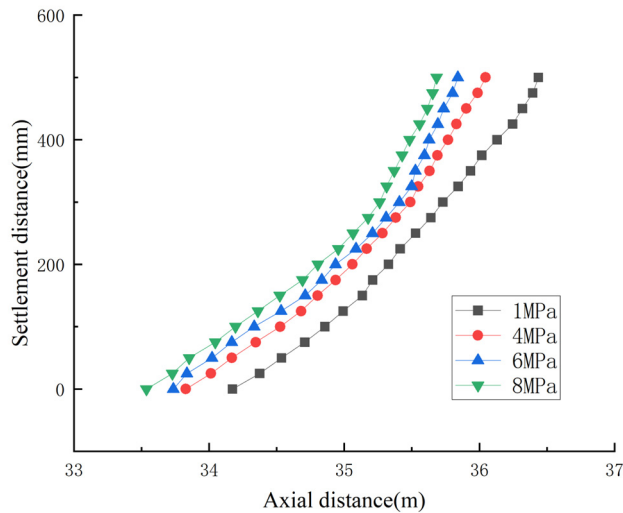

Fig 6. Position curve of the maximum compressive strain under different internal pressures

From Fig.5, the initial pipeline strain increases with increasing of internal pressure under different internal pressures. There is a correlation between the change trend of the curve and the internal pressure size. The maximum tension strain increases when the linear stage is the longest. As the linear pressure becomes smaller, the maximum tension strain mutation appears earlier and the trend becomes more urgent, and the maximum tension strain increases from 1.45×10^{-3} to 1.61×10^{-3} . Under the action of excessive internal pressure, the pipeline will have a relatively large strain, which is unfavorable to the safe operation of the pipeline. It can be seen from Fig.6 that the maximum compression position changes similarly under different internal pressures, and the maximum compressive strain position gradually slows down as the settlement increases, and the maximum initial strain position when the internal pressure increases move to the settlement area.

3.2. Influence of Pipe Wall Thickness

If the internal pressure is 2MPa and other conditions remain unchanged, pipelines with wall thickness of 8mm, 10mm, 14mm and 20mm are established to analyze the strain distribution of the wall thickness of pipelines. See Fig.7 for the change pattern of the maximum compressive strain with settlement, and the change curve of the maximum compressive strain position is shown in Figure 8.

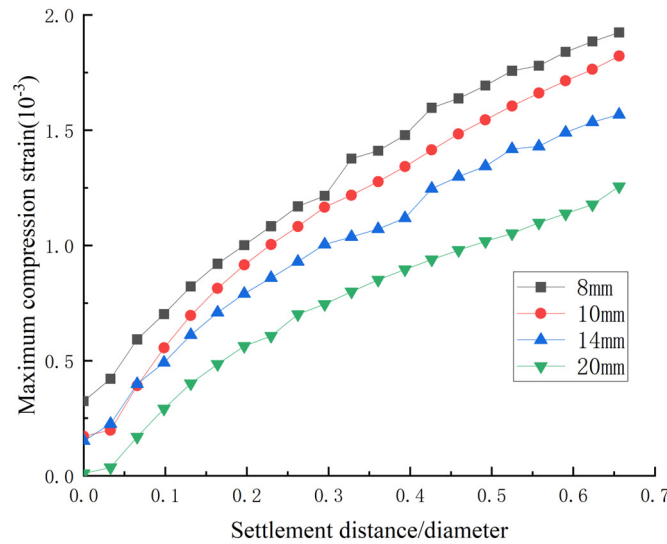

Fig 7. Maximum axial compression strain curve under different wall thicknesses

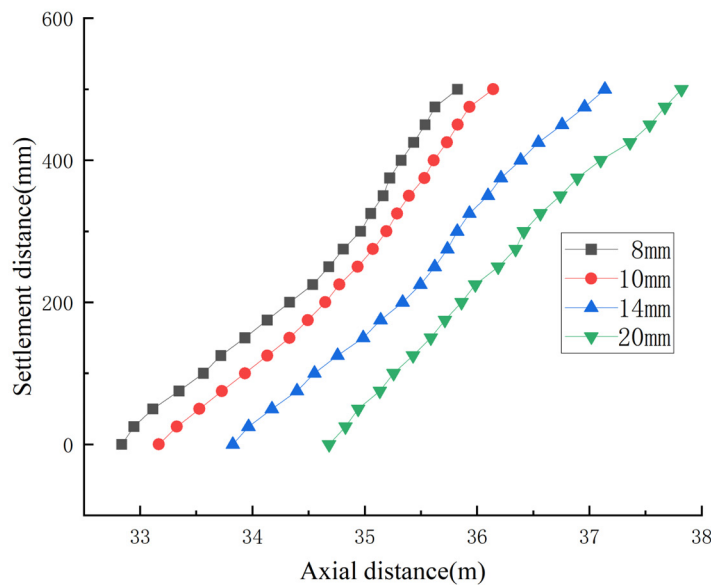

Fig 8. Position change curve of the maximum compressive strain under different wall thicknesses

As can be seen from Fig.7, the maximum pressure strain of the pressure pipe starts to change very little. Then, as the settlement increases linearly, when the settlement increases to 150mm, the pipe with a wall thickness of 8mm enters the nonlinear stage first. The maximum compressive strain of the pipe appears in the area above the pipe, and the maximum value decreases. As can be seen from Fig.8, the change curve of the maximum compressive strain

under different wall thickness is similar, which all have the trend of slow and slow change. The thicker the wall thickness, the greater the initial maximum compression strain, the change trend of the 8mm wall thickness is 220mm, and the curve trend changes when the settlement of the 20mm wall thickness is 400mm. In the actual construction, the selection of large wall thick pipeline is conducive to the safe operation.

3.3. Influence of Different Settlement Amount

The strain variation curve in the axial direction was plotted based on the simulated experimental data of different settlements.

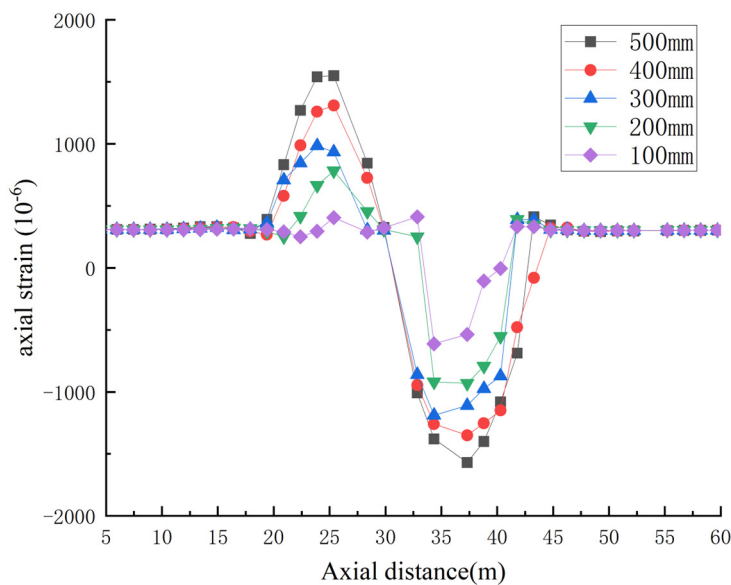

Fig 9. axial strain change curve under different settlements

As shown in Fig.9, the compressive strain of the same settlement is greater than the tensile strain, and the difference of the compressor strain gradually decreases as the settlement increases, and the axial strain is mainly the compressor strain. According to the 100mm settlement, the tensile strain on the upper surface of the pipeline begins to settle is very small, which can be ignored. When the settlement reaches 500mm, the tension strain size is basically the same, indicating that the tension and compression strain will affect the safety of the pipeline when the settlement is large.

4. Conclusion

Based on abaqus finite element software, the finite element calculation model of buried natural gas pipeline-soil is established, and the change of pipeline strain in the process of uneven settlement is analyzed based on the settlement data and pipeline data in actual engineering.

Under the action of uneven settlement, the local deformation of the pipeline in the soil settlement area gradually deviates to the non-settlement area with the increase of the wall thickness, the local deformation gradually disappears, and the peak axial strain gradually becomes smaller. Laying large wall thick pipe in easy settling area can effectively reduce pipe strain and improve safety.

The strain between the upper surface and the lower surface of the pipeline is obvious. With the gradual increase of the internal pressure, it is close to 0 away from the settlement area. After the pipeline is affected by uneven settlement, and the deformation is more obvious after the

greater the axial stress. The influence of internal pressure on deformation is less than that of wall thickness.

For the X100 pipeline in this simulation, as the settlement gradually increases, the initial strain first appears at the edge of the settlement area, and the peak gradually shifts to both ends, and the trend becomes slower after reaching the peak, and gradually decreases to negligible outside 2 times the pipe diameter in the settlement area.

Acknowledgments

Taking the long buried natural gas pipeline as the object, the coupling field failure criterion of the long buried natural gas pipeline is established. Theoretical analysis of coupling field in long-buried natural gas pipeline. Failure behavior of long-term buried natural gas pipeline under multifield coupling action. Establishment of failure criterion of long-term buried natural gas pipeline under multi-field coupling action.

This research work was supported by the National Natural Science Foundation of Hebei Province China (No. E2020209072) and Industry University Cooperation Collaborative Education Project of the Ministry of Education (No.220505308045106).

References

- [1] The National Bureau of Statistics of China. The BRICS Joint Statistical Manual [M]. Beijing: China Statistics Press, 2022.02.
- [2] Jia Chengzao, Zhang Yongfeng, Zhao Xia. Development prospects and Challenges of China's natural gas industry [J]. Natural Gas Industry, 2014,34 (02): 8 -18.
- [3] Yimsiris, Sogak, Yoshizakik, et al. Lateral and upward soil-pipe interactions in sand for deep embedment conditions[J]. Geotechnical and Geoenvironmental Engineering, 2004, 130(8):830-842.
- [4] Liu Chunguang, Ke Guomin. Numerical simulation analysis of buried pipelines in the liquefaction area [J]. World Seismic Engineering, 2010,26(01):125-130.
- [5] Jin Liu, Wang Su, Du Xiuli. Analysis of buckling reaction of buried pipelines under site subsidence [J]. World Seismic Engineering, 2011,27(02):142-147.
- [6] Popov A B. Calculated analysis of the stressed and strain state of pipeline sector elbows[J]. Thermal Engineering, 2012, 59(4):289-294.
- [7] Kunert H G, Otegui J L, Marquez A. Nonlinear FEM strategies for modeling pipe-soil interaction[J]. Engineering Failure Analysis, 2012, 24(24):46-56.
- [8] Balkaya M, Moore I D, Saglamer A. Study of nonuniform bedding due to voids under jointed PVC water distribution pipes[J]. Geotextiles and Geomembranes, 2012,34:39-50.
- [9] Wu Shaoyan, Wen Baoping. The influence of the thickness of the quaternary overburden on the deformation of the surface and buried oil transport pipeline in the goaf of the underground coal seam [J]. Science, Technology and Engineering, 2014,14 (25): 146-150 + 176.
- [10] Li Yukun, Wu Zhonglin, Li Longjie, et al. Calculation of buried pipeline stress of uneven settlement reclamation foundation [J]. Oil and gas storage, 2014,33 (03): 247-251.
- [11] Zhang Yinan, Ma Guiyang, Zhou Wei, et al. Analysis of the influence of settled soil on the stress of pipe crossing structure [J]. China Safety Production Science and Technology, 2015,11 (08): 106-111.
- [12] Zhang S Z, Li S Y, Chen S N, et al. Stress analysis on large-diameter buried gas pipelines under catastrophic landslides[J]. Petroleum Science, 2017, 14(3):579-585.
- [13] Zhou Qichao. Study on stress analysis and countermeasures of buried natural gas pipeline under uneven settlement [D]. Master Degree Candidate, South China University of Technology, China 2018.
- [14] Liu Wei, Huang Chunjie. Numerical analysis of buried pipeline response under uneven settlement of ground surface [J]. Journal of Tongji University (Natural Science Edition), 2022,50 (03): 370-377.

- [15] Ma Xiaoming, Jandi. Analysis of safe operation of coastal natural gas buried pipeline under uneven settlement [J]. Chemical Machinery, 2023,50 (01): 76-82.
- [16] Gong Shaotao, Wang Aimin, Ji Linggang, et al. Study on the difference between the yield strength of $R_{t0.5}$ and $R_{t0.5}(p0.2)$ [J]. Welded pipe, 2007 (05): 42-44 + 106.
- [17] Zheng JY, Zheng BJ, Liu PF, et al. Failure analysis and safety evaluation of buried pipeline due to deflection of landslide process [J]. Engineering Failure Analysis, 2012, 25: 156.
- [18] Song Xiaojuan, Peng Xingyu, Dou Xuzhao, et al. Stress analysis of buried gas PE pipeline under the action of ground subsidence [J]. Industrial safety and environmental protection: 2023, 8: 1-7.
- [19] Xu Ping: Study on the interaction and mechanical response of the buried pipeline and soil under the influence of mining subsidence [D]. Master Degree Candidate, China University of Mining and Technology, China 2015.