

Study on Support Technology of Truss Anchor Cable Beam in Deep Soft Rock Roadway Excavation

Shiwei Wang^{1, 2}

¹China Coal Technology and Engineering Group Chongqing Research Institute, Chongqing 400037, China

²State Key Laboratory of Coal Mine Disaster Prevention and Control, Chongqing 400037, China

Abstract

Aiming at the difficult problem of soft rock roadway support in deep mine, the support mode of "truss anchor beam" is proposed, and the support mode technology of truss anchor beam in deep soft rock roadway driving is studied by FLAC simulation software. Combined with the measured displacement of coal and rock around underground roadway under this support mode, it is concluded that the truss anchor beam support mode can introduce the high stress of shallow coal and rock around roadway into deep area, thus effectively controlling the deformation of coal and rock around roadway and ensuring safe and efficient production of mine.

Keywords

Deep Soft Rock; Truss Anchor Beam; Deformation of Surrounding Rock; Roadway Support.

1. Engineering Background

As coal mining extends deeper, the geological conditions underground become increasingly complex, resulting in increased ground stress and high ground temperature [1-3]. The deep rock mass exhibits the characteristics of soft rock, leading to deformation and expansion of the surrounding rock of the roadway, making it more difficult to support the roadway [4-6]. Therefore, the safety support of soft rock tunnels during deep mining is extremely important. In recent years, domestic scholars have conducted in-depth research on the support technology of deep soft rock tunnels [7-10].

A certain mine in Shanxi has a production capacity of 1.2 million tons per year. The No.2 coal seam is currently being mined, with an average thickness of 1.8m and a maximum mining depth greater than 800m, belonging to a high gas mine. According to geological survey data, the geological structure of the No.2 coal seam belongs to a simple type, with stable coal seam occurrence and a dip angle of 2° to 8°, with an average of 5°. The roof is composed of mudstone, siltstone, and fine-grained sandstone, which belong to the soft rock roof. The working face is excavated along the bottom plate of the No.2 coal seam, with a tunnel section of 5m (width) × 3m (height), using a full face excavation method of one-time tunneling. Therefore, based on this, the support technology of truss anchor beam was proposed, and the feasibility of this support method was analyzed by combining FLAC simulation software and on-site support effect monitoring.

2. Numerical Simulation of Truss Anchor Beam Support

(1) Truss anchor beam structure

The truss anchor beam support is a combination of anchor cables, anchor rods, ladder beams, and metal mesh support. Truss anchor cable support is carried out on the top plate and two sides, with a set of truss anchor cable beams arranged between every two rows of anchor cables and anchor rods, forming a set of anchor cable beam system. The support method of truss anchor beam is shown in Figure 1.

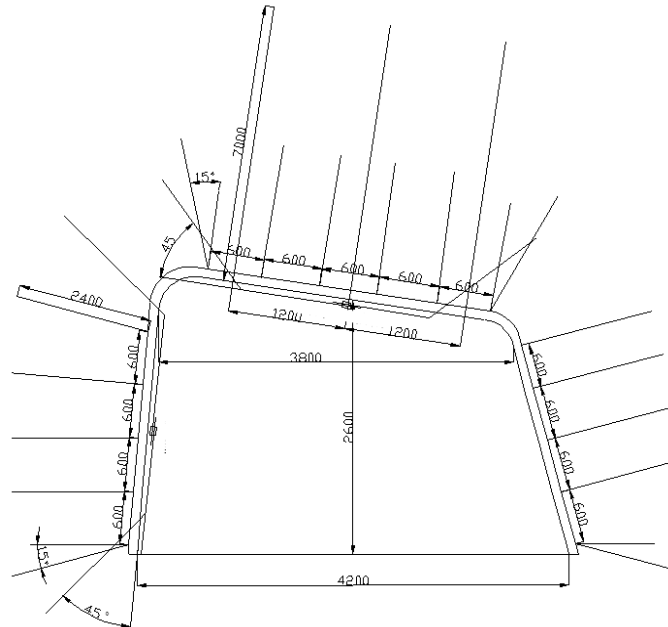

Figure 1. Schematic diagram of truss anchor beam support

(2) Establishment of model

Using FLAC simulation software, the support method of truss anchor beam in deep well soft rock excavation roadway was studied, and a numerical model (model size 200m x 100m) was established. According to the burial depth of coal seam 2, the overlying rock layer of the roadway is calculated at 800m, with an average density of 2400kg/m³. A self weight stress of 19.2MPa is applied, and displacement boundary constraints are used on the left and right sides of the model. Based on the comprehensive bar chart of the No.2 coal seam, determine the lithology and mechanical parameters of the overlying rock layers. The mechanical parameters of each rock layer are shown in Table 1.

Table 1. Mechanical parameters of each rock layer

Roof lithology	<i>h</i> /m	γ /g.cm ⁻³	<i>R_c</i> /MPa	<i>R_t</i> /MPa	<i>C</i> /MPa	Φ /°	<i>E</i> /GPa	μ
1 Siltstone	5.68	2.5	18	1.81	2.70	36	11.05	0.22
2 fine sandstone	1.4	2.64	40	1.80	4.25	37	11.65	0.21
3 mudstone	5.5	2.32	14	1.12	0.52	30	4.38	0.32
4 Siltstone	7	2.5	18	1.81	2.70	36	11.05	0.22

(3) Analysis of numerical simulation results

The truss anchor beam support is based on the universal support method of "anchor rod, anchor cable, and metal mesh", and adds truss anchor beam support to the roof and two sides of the roadway. The model of the truss anchor beam support method is shown in Figure 2.

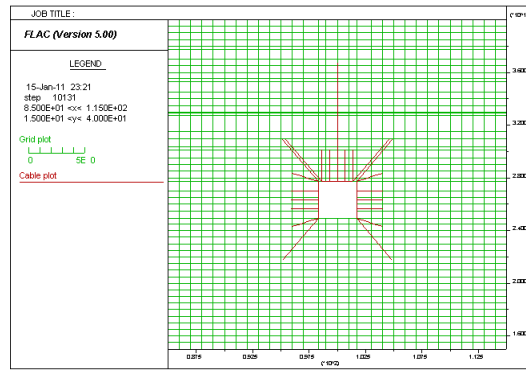
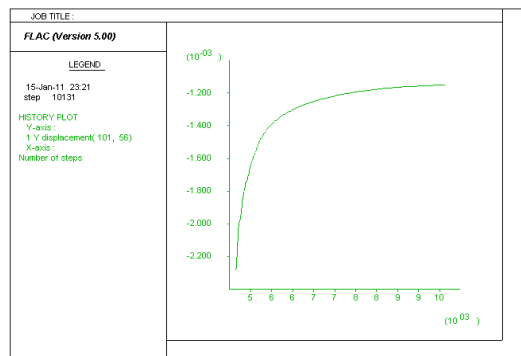
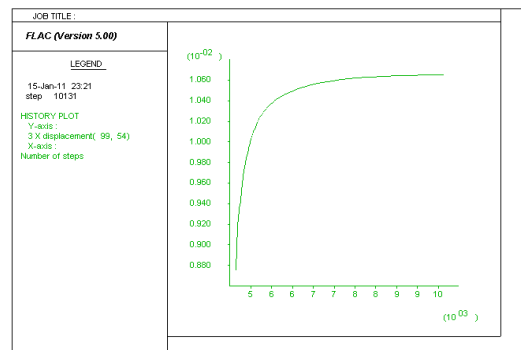

Figure 2. Model diagram of support scheme

The displacement monitoring curve of the surrounding rock of the tunnel under the condition of truss anchor beam support is shown in Figure 3.



(a)Monitoring for roof subsidence



(b)Deformation monitoring for both sides of the roadway

Figure 3. Monitoring of deformation of surrounding rock in tunnels

According to the analysis of the monitoring curve of the surrounding rock in Figure 3, it can be seen that under the conditions of truss anchor beam support, the deformation of both sides of the tunnel is 0.0106m, and the subsidence of the roof is 0.012m. Through numerical simulation analysis, it is known that truss anchor beam support can effectively control the deformation of the tunnel roof and two sides, thereby reducing the maintenance cost of tunnel deformation.

Under the conditions of truss anchor beam support, the stress contour of the surrounding rock of the tunnel is shown in Figure 4.

According to the analysis in Figure 4, it can be seen that under the conditions of truss anchor beam support, the horizontal stress concentration area around the roadway is located at the two corners of the roadway roof, and the vertical stress concentration area is located at the two corners of the roadway roof and the deep areas of the left and right roadway sides. Under the

conditions of truss anchor beam support, high stress in the shallow part of the roadway can be introduced into the deep rock mass, fully mobilizing the bearing capacity of the deep rock mass and reducing the deformation of the surrounding coal rock mass.

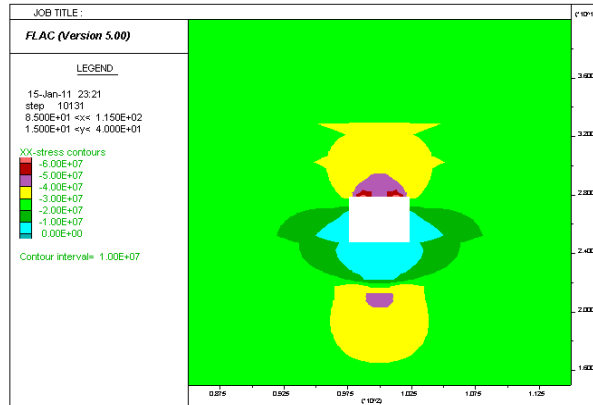

(a) Horizontal direction

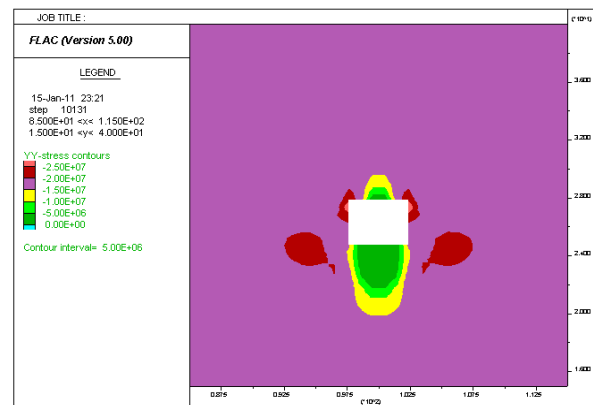

(b) Vertical direction

Figure 4. Stress contour map of tunnel surrounding rock

3. Monitoring of On-site Support Effectiveness

(1) Layout of measuring points

The "cross crossing" method was used on site to measure the deformation of the coal and rock mass around the tunnel. Short anchor rods were used to set fixed points on the roof and two sides, and the deformation of the fixed points was continuously observed underground. The layout of the measurement points is shown in Figure 5.

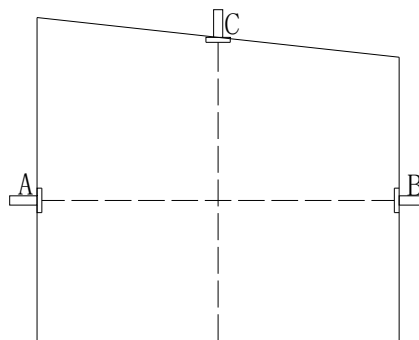

Figure 5. Schematic diagram of tunnel deformation monitoring

In order to compare and analyze the support effect of truss anchor beam, three observation points were arranged in 12212 wind tunnel, namely KD0, KD1, and KD2. KD0 was located under the support conditions of "anchor rod, anchor cable, and metal mesh", while KD1 and KD2 were located under the support conditions of "anchor rod, anchor cable, metal mesh" and truss anchor beam. The displacement and deformation of the top plate and two sides of each observation point were observed continuously for more than 3 months, as shown in Figures 6 to 8.

(2) Data observation and comparative analysis

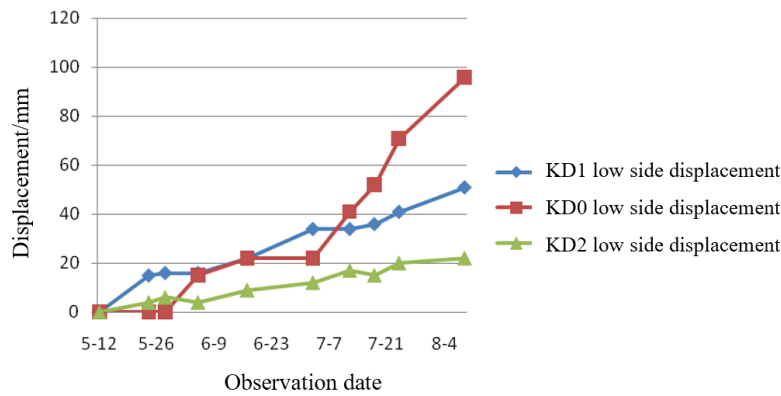

Figure 6. Distribution of convergence deformation in OA section of high wall wind tunnel

From Figure 6, it can be seen that during the observation period at each measuring point, the displacement and deformation of KD0, KD1, and KD2 on the high side of the 12212 airway are 51mm, 96mm, and 22mm, respectively. Data analysis shows that the use of truss anchor beam support can effectively control deformation of the high wall of the roadway.

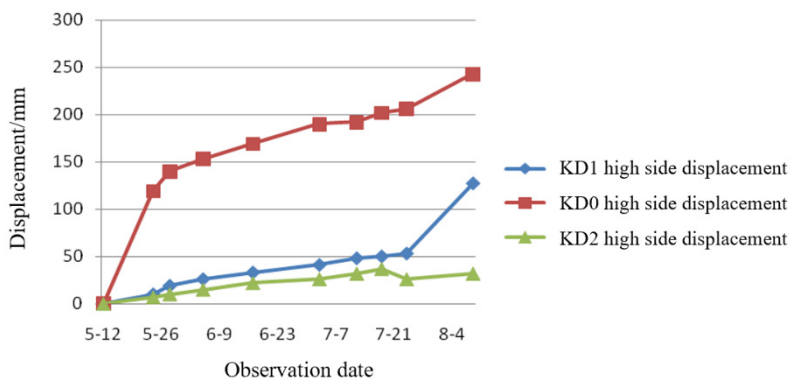

Figure 7. Distribution of convergence deformation in OB section of the wind tunnel

From Figure 7, during the observation period at each measuring point, the displacement and deformation of KD0, KD1, and KD2 on the low side of the 12212 airway were 239mm, 132mm, and 29mm, respectively. Data analysis shows that the use of truss anchor beam support effectively controls deformation on the low side of the roadway.

From Figure 8, it can be seen that the subsidence of the top plates of KD0, KD1, and KD2 in the 12212 wind tunnel are 178mm, 80mm, and 31mm, respectively. The subsidence of the top plates at measurement points KD1 and KD2 is much smaller than that at measurement point KD0. Therefore, the truss anchor beam support method can effectively control the subsidence of the top plates.

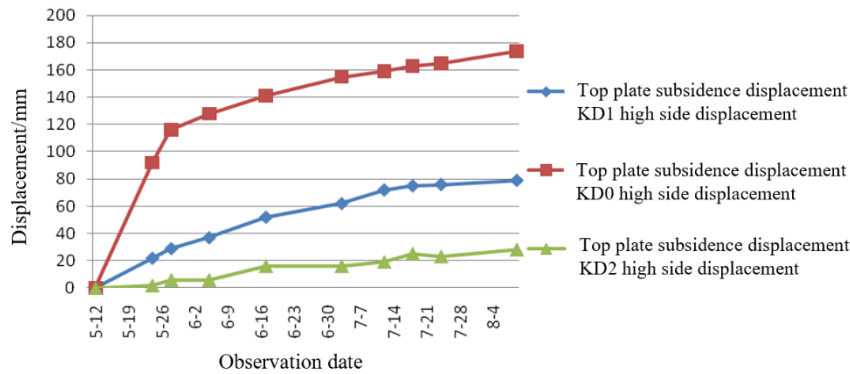

Figure 8. Distribution of convergence deformation for OC section of wind tunnel roof

4. Conclusion

Using FLAC numerical simulation and on-site support effect monitoring, the support method of truss anchor beam was studied, and the following conclusions were drawn:

- (1) Through numerical simulation analysis, it is known that under the conditions of truss anchor beam support, high stress in the shallow part of the roadway is introduced into the deep rock mass, fully mobilizing the bearing effect of the deep rock mass, effectively controlling the deformation of the roadway roof and two sides, and reducing the maintenance cost of roadway deformation.
- (2) Through on-site measurement data analysis, it is known that under the conditions of truss anchor beam support, the displacement and deformation of the roadway and the subsidence of the roof have been greatly reduced, achieving good support effects.

References

- [1] Cao Anye, Guo Wenhao, Wen Yingyuan, et al. Classification of anchor "Beam Arch" structures and mechanism of top impact instability in supporting top coal tunnels [J/OL]. *Journal of China Coal Society*: 1-20 [2024-04-18].
- [2] Ren Shuai, Lu Dechao, Luo Yong, et al. Creep instability mechanism and key control technology of soft rock roadway surrounding rock in deep mines [J]. *Safety in Coal Mines*, 2024,55 (03): 190-198.
- [3] Wang Nengyue, Wang Kun, Wang Shibo. Analysis of instability mechanism and optimization of support in deep soft fractured rock roadway [J]. *Nonferrous Metals (Mining Part)*, 2023,75 (05): 43-51.
- [4] Li Chunyuan, Cui Chunyang, Lei Guorong, et al. Mechanism of rock mass confining pressure unloading seepage induced tensile fracture in deep mining [J]. *Journal of Coal Mining*, 2022, 47 (08): 3069-3082.
- [5] Jiang Quan, Shi Yingen, Cai Meifeng, et al. Large deformation law of deep rock mass: comprehensive observation and research on deformation and failure of tunnels in Jinchuan No.2 Mine [J]. *Journal of Coal Science*, 2019, 44 (05): 1337-1348.
- [6] Han Xinming. Optimization of coal pillar size and research and application of grouting anchor cable strengthening support [J]. *Shandong Coal Technology*, 2024,42 (02): 1-5.
- [7] Yang Juncai, Fan Donglin, Chen Sushe, et al. Application of anchor cable active advance support technology in the mining roadway of Bulianta Coal Mine [J]. *Coal Engineering*, 2024,56 (02): 59-65.
- [8] Zhang Qiumao, Dong Shichao. Research on full anchor support technology for coal roadway excavation in Yangdong Mine [J]. *Coal and Chemical Industry*, 2023,46 (11): 6-9+13.
- [9] Wang Bingzhen, Zhao Shuhong. Research and practice on combined support of high stress three soft coal roadway anchor and steel shed [J]. *Shandong Coal Technology*, 2022, 40 (04): 67-69.
- [10] Zhang Lei. The application of anchor net spraying and anchor cable support technology in coal chute maintenance [J]. *Mechanical Management Development*, 2019,34 (06): 146-147+165.