



Research Article

THE POSSIBILITY OF APPLYING THE THEORY OF ADAPTIVE IDENTIFICATION TO AUTOMATE MULTI-CONNECTED OBJECTS

Submission Date: February 28, 2022, **Accepted Date:** March 20, 2022,

Published Date: March 31, 2022 |

Crossref doi: <https://doi.org/10.37547/tajet/Volume04Issue03-05>

Journal Website:

<https://theamericanjournals.com/index.php/tajet>

Copyright: Original content from this work may be used under the terms of the creative commons attributes 4.0 licence.

Umid Kholmatov

Senior Lecturer, Andijan machine-building institute, Andijan, Uzbekistan

ABSTRACT

The article proposes solutions to the problem of using the theory of adaptive identification for automation of multiply connected objects and shows the possibilities of applying the theory of adaptive identification of multiply connected objects using the example of wastewater treatment plants.

KEYWORDS

Discrete systems, adaptive identification, matrix coefficients, compound vectors, block diagram.

INTRODUCTION

It is known that numerous tasks of managing production processes and complex installations, which include chemical and biological wastewater treatment, are multi-connected objects that require a transition from automation of individual processes to automation of production complexes.

Automation of industrial complexes leads to the need to take into account the interconnectedness of the input and output coordinates of individual processes, and, consequently, the structural links between them. The lack of sufficiently complete a priori information about the object, the laws of distribution of random

parameters and random influences makes it necessary to apply the theory of adaptive identification. In the future, adaptive identification of multiply connected objects will be understood as the determination of the parameters and structure of objects under conditions of initial uncertainty, based on the results of monitoring the change in input and output values during normal operation. From this point of view, of particular interest are the electric power systems of drainage and treatment facilities, in which the frequency and voltage, active and reactive power flows, the performance of turbocompressors of pumping stations are simultaneously regulated, and according to the technological mode they are treated as multi-connected objects with separate control channels, operating modes [1-2].

The parameters of the control object, for example, water disposal and treatment facilities vary over a wide range [1-3]. If we assume that only one factor affects the change in the parameters of the object (for example, the concentration of waste water), while neglecting the operating modes of turbocompressors and pumping units, then it is not possible to use the obtained parameters of the control object without large errors. If we solve the problem of identifying treatment facilities as a multiply connected object, taking into account all the indicated values during operation, then the parameters of the object obtained in this case will be determined much more accurately [4].

METHODS

The task of adaptive identification arises due to the fact that, in the general case, the internal and external influence that acts on the object is of a random

nature. For water treatment facilities as objects, this randomness is due to the random nature of the disturbing moments and other factors caused by the uneven distribution of pump motor power, the instability of pressure in turbocompressors from cycle to cycle, the concentration of activated sludge, the dose of active chlorine, etc [4, 6-8]. For treatment facilities, such impacts are: filling of sedimentation tanks and aerotanks, failure of one of the symmetrically located engines and pumps, etc.

It is easy to determine the distribution laws for each of these factors separately [5], but it is almost impossible to determine the resulting distribution law for the entire set of factors, and, accordingly, the identifiable object parameters that depend on them. In this regard, the problem of identifying multiply connected objects is reduced to the problem of adaptive identification.

Currently, there is no complete theory of adaptive identification of multiply connected objects. In this article, some questions of the theory of adaptive identification of multiply connected objects containing forward and reverse cross-links are presented.

RESULTS AND DISCUSSION

Generalization of the equation of dynamics of multiply connected objects.

Let us describe processes in multiply connected objects of a system of linear inhomogeneous l -th order differential equations with r unknown variables x_1, x_2, \dots, x_r of the argument t with constant coefficients

$$\sum_{j=1}^r a_{ij}(D)x_j = \sum_{j=1}^r b_{ij}(D)v_j \quad (1)$$

where the set of coordinates $\bar{x} = \{x_1, x_2, \dots, x_r\}$; $\bar{v} = \{v_1, v_2, \dots, v_r\}$ - vectors - columns of object state and control, respectively; i - number of a separate channel; $D=d/dt$ – differentiation operator; $a_{ij}(D), b_{ij}(D)$ - are polynomials in D , that have the form

$$a_{ij}(D) = a_{ij}^{(l)} D^l + a_{ij}^{(l-1)} D^{l-1} + \dots + a_{ij}^{(1)} D + a_{ij}^{(0)}; \quad (2)$$

$$b_{ij}(D) = b_{ij}^{(l_1)} D^{l_1} + b_{ij}^{(l_1-1)} D^{l_1-1} + \dots + b_{ij}^{(1)} D + b_{ij}^{(0)};$$

Here $i, j=1, 2, \dots, r$; l, l_1 - the order of the polynomial of the coefficients a and b , respectively; r is the number of separate channels of the controlled object. It is assumed that the number of direct cross-links is equal to the number of reverse ones; the order of differential equations of reverse cross-links is equal to the order of differential equations of direct cross-links. These assumptions do not reduce the generality of the problem, since in the presence of any other options and combinations of cross-couplings, as well as the order of differential equations, it is reduced to special cases. Let us introduce numerous matrices of operator coefficients [1-2]:

$$\begin{aligned} A(D) &= \| \| a_{ij}(D) \| \|; \\ B(D) &= \| \| b_{ij}(D) \| \|; \end{aligned} \quad (3)$$

or expanded

$$A(D) = \left\| \left\| \begin{array}{ccc} a_{11}(D) & a_{12}(D) & \dots & a_{1r}(D) \\ a_{21}(D) & a_{22}(D) & \dots & a_{2r}(D) \\ \dots & \dots & \dots & \dots \\ a_{r1}(D) & a_{r2}(D) & \dots & a_{rr}(D) \end{array} \right\| \right\|; \quad (4)$$

$$B(D) = \left\| \left\| \begin{array}{ccc} b_{11}(D) & b_{12}(D) & \dots & b_{1r}(D) \\ b_{21}(D) & b_{22}(D) & \dots & b_{2r}(D) \\ \dots & \dots & \dots & \dots \\ b_{r1}(D) & b_{r2}(D) & \dots & b_{rr}(D) \end{array} \right\| \right\|;$$

Sloping

$$A_k = \| \| a_{ij}^{(k)} \| \| (i, j = 1, 2, \dots, r;$$

$$k=0, 1, 2, \dots, l; \quad (5)$$

$$B_q = \| \| b_{ij}^{(q)} \| \| (q = 0, 1, 2, \dots, l_1),$$

one can represent multiple matrices $A(D)$ in $B(D)$ as polynomials with matrix coefficients

$$A(D) = A_l D^l + A_{l-1} D^{l-1} + \dots + A_1 D + A_0;$$

$$B(D)=B_{11}D^1+B_{1-1}D^{1-1}+\dots+B_1D+B_0; \quad (6)$$

Then, in matrix form, the system of differential equations (1) takes the form

$$\sum_{k=0}^l A_k D^k x = \sum_{q=1}^{l_1} B_q D^q \bar{u} \quad (7)$$

In expanded form, for any separate channel, one can write

$$\sum_{k=0}^l \sum_{j=1}^r a_{ij}^{(k)} D^k x_j = \sum_{q=0}^{l_1} \sum_{j=1}^r b_{ij}^{(q)} D^q u_j \quad (8)$$

Let us rewrite equation (8) in a difference form (in a recurrent form):

$$x_i[n] = \sum_{k=0}^l \sum_{j=1}^r c_{ij}^{(k)} x_i[n-k] + \sum_{q=1}^{l_1} \sum_{j=1}^r d_{ij}^{(q)} u_j[n-q] \quad (9)$$

The matrix coefficients of the equations are interconnected by relations [1-2].

$$c_{ij}^{(l-k)} = -\sum_{v=0}^k a_{ij}^{(l-v)} (-1)^{k-v} c_{l-v}^{k-v};$$

$$a_{ij}^{(l_1-q)} = -\sum_{v=0}^q a_{ij}^{(l_1-v)} (-1)^{q-v} c_{l_1-v}^{q-v};$$

where

$$c_{l-v}^{k-v} = \frac{(1-v)!}{(k-v)! (l-k)!};$$

$$c_{l_1-v}^{q-v} = \frac{(1_1-v)!}{(q-v)! (l_1-k)!};$$

For a controlled object in the presence of only direct cross-links, equation (9) has the form

$$x_i[n] = \sum_{m=1}^l c_{ii}^{(m)} x_i[n-m] + \sum_{j=1}^r \sum_{m=1}^S d_{ij}^{(m)} v_j[n-m], \quad (9.a)$$

and in the presence of only inverses -

$$x_i[n] = \sum_{j=1}^r \sum_{m=1}^S c_{ij}^{(m)} x_i[n-m] + \sum_{m=1}^l d_{ij}^{(m)} v_i[n-m], \quad (9.6)$$

In some cases, some of the coefficients c_{ii}^m and d_{ij}^m may be equal, which corresponds to the absence of any links.

General algorithm for adaptive identification of multiply connected stationary objects.

To solve the identification problem, we introduce a composite situation vector. By analogy with [4], we denote the situation vector \bar{Z} , and the composite vector - \bar{t} .

Consider a multiple composite vector of coefficients:

$$\hat{c}_\mu = f_\mu(c_{ij}^\mu) = f_c(c_{11}^\mu, c_{12}^\mu, \dots, c_{1r}^\mu; c_{22}^\mu, c_{22}^\mu, \dots, c_{2r}^\mu; \dots; c_{1r}^\mu, c_{r2}^\mu, \dots, c_{rr}^\mu; d_{11}^\mu, d_{12}^\mu, \dots, d_{r1}^\mu; \dots; d_{r1}^\mu, d_{r2}^\mu, \dots, d_{rr}^\mu) \quad (10)$$

It should be noted that the dimension of the multiple composite vector \hat{c}_μ depends on the dimension of the system and the order of the difference equation (9).

Let us express the composite situation vector \vec{Z} in terms of the vector \vec{Z} :

$$\vec{Z}[n] = \varphi_z(\vec{Z}_i[n]) = \varphi_z(x_{i1}, x_{i2}, \dots, x_{ir}, v_{i1}, v_{i2}, \dots, v_{ir}), \quad (11)$$

Where

$$\vec{Z}_i[n] = \{x_i[n-1], x_i[n-2], \dots, x_i[n-l], v_i[n-1], v_i[n-2], \dots, v_i[n-l_1]\}.$$

The quality of identification is estimated using functionals from control errors, which are integral root-mean-square estimates. Therefore, each of them is expressed through the mathematical expectation, taking into account the stochastic nature of all influences [1-2]. In the general case, we write the optimality criterion in the form

$$J(\hat{c}, \hat{d}) = M\{F[\vec{x}[n] - \hat{c}^m \vec{\varphi}(x)[n]] - \hat{d}^m \vec{\varphi}(v)[n]\}$$

The adaptive identification algorithm in this case will have the form

$$\hat{c}[n] = \hat{c} + \Gamma_x[n] F'_x(\vec{x}[n] - \hat{c}^m[n-1] \vec{\varphi}_x(x[n]) - \hat{d}^m[n-1] \vec{\varphi}_u(v[n])) \vec{\varphi}(x[n]);$$

$$\hat{d}[n] = \hat{d}[n-1] + \Gamma_u[n] F'_u(\vec{x}[n] - \hat{c}^m[n-1] \vec{\varphi}_x(x[n]) - \hat{d}^m[n-1] \vec{\varphi}_u(v[n])) \vec{\varphi}(v[n]), \quad (13)$$

Where $\Gamma_x[n]$ и $\Gamma_u[n]$ – diagonal coefficient matrices $\gamma_{ij}^k (k=x, u)$,

$$\Gamma_k[n] = \begin{vmatrix} \gamma_{11}^k & 0 & 0 & 0 & 0 \\ 0 & \gamma_{22}^k & 0 & 0 & 0 \\ \dots & \dots & \dots & \dots & \dots \\ 0 & 0 & 0 & 0 & \gamma_{rr}^k \end{vmatrix}.$$

The block diagram of a discrete system corresponding to the identification algorithm (13) in vector form is shown in Fig.1. Algorithm (13) can be expressed in expanded form in terms of composite vectors

$$\vec{c}^\mu[n] = \vec{c}^\mu[n-1] + \Gamma_x[n] x \left(\vec{x}[n] - \sum_{v=1}^l \vec{c}^v[n-1] \overline{\varphi_{xv}}(x)[n] \right) - \sum_{q=1}^{l_1} \vec{d}^q[n-1] \overline{\varphi_{qu}}(v[n]) \overline{\varphi_{\mu x}}(x[n]);$$

$$\vec{d}^\rho[n] = \vec{d}^\rho[n-1] + \Gamma_u[n] x \left(\vec{x}[n] - \sum_{v=1}^l \vec{c}^v[n-1] \overline{\varphi_{vx}}(x)[n] \right) - \sum_{q=1}^{l_1} \vec{d}^q[n-1] \overline{\varphi_{qu}}(v[n]) \overline{\varphi_{\rho u}}(v[n]), \quad (14)$$

Where $\mu, \nu=0, 1, 2, \dots, l$; $q, p=1, 2, \dots, l$; $\vec{c}^\mu=(c_{11}^\mu, c_{12}^\mu, \dots, c_{1r}^\mu; c_{21}^\mu, c_{22}^\mu, \dots, c_{2r}^\mu; \dots; c_{r1}^\mu; c_{r2}^\mu, \dots, c_{rr}^\mu)$; $\vec{d}^p=(d_{11}^p, d_{12}^p, \dots, d_{1r}^p; d_{21}^p, d_{22}^p, \dots, d_{2r}^p; \dots; d_{r1}^p, d_{r2}^p, \dots, d_{rr}^p)$.

$$\bar{\varphi}_{\mu x}(x[n]) = \bar{x}[n - \mu];$$

$$\varphi_{\mu x}(x[n]) = \bar{x}[n - \mu];$$

$$\bar{\varphi}_{qu}(v[n]) = \bar{v}[n - q];$$

$$\bar{\varphi}_{pu}(v[n]) = \bar{v}[n - p]. \tag{15}$$

In expression (14), the functions $\bar{\varphi}(x[n])$ and $\bar{\varphi}(v[n])$ are $\bar{\varphi}_{vx}(x[n]) = \bar{x}[n - \nu]$;

Taking into account the values of functions (15) for the quadratic functional, algorithm (14) is transformed to the form

$$\check{c}^\mu[n] = \check{c}^\mu[n - 1] + \Gamma_x[n](\bar{x}[n] - \sum_{v=0}^l c^v[n - 1] \bar{x}[n - v] - \sum_{q=1}^{l_1} \vec{d}[n - 1] \bar{v}[n - q]) \bar{x}[n - \mu]; \tag{16}$$

In expression (14), the functions $\bar{\varphi}(x[n])$ and $\bar{\varphi}(v[n])$ are $\bar{\varphi}_{vx}(x[n]) = \bar{x}[n - \nu]$;

Taking into account the values of functions (15) for the quadratic functional, algorithm (14) is transformed to the form

$$\check{c}^\mu[n] = \check{c}^\mu[n - 1] + \Gamma_x[n](\bar{x}[n] - \sum_{v=0}^l c^v[n - 1] \bar{x}[n - v] - \sum_{q=1}^{l_1} \vec{d}[n - 1] \bar{v}[n - q]) \bar{x}[n - \mu]; \tag{16}$$

$$\vec{d}^\mu[n] = \vec{d}^\mu[n - 1] + \Gamma_u[n] \left(\bar{x}[n] - \sum_{v=0}^l c^v[n - 1] \bar{x}[n - v] - \sum_{q=1}^{l_1} \vec{d}^p[n - 1] \bar{v}[n - q] \right) \bar{v}[n - p];$$

CONCLUSION

The above algorithms allow solving problems from the transition of automation of individual processes to automation of industrial complexes, and determine the possibilities of applying the theory of adaptive identification of multiply connected objects, as well as

consider complex issues of compiling identification algorithms by using an iterative probabilistic method.

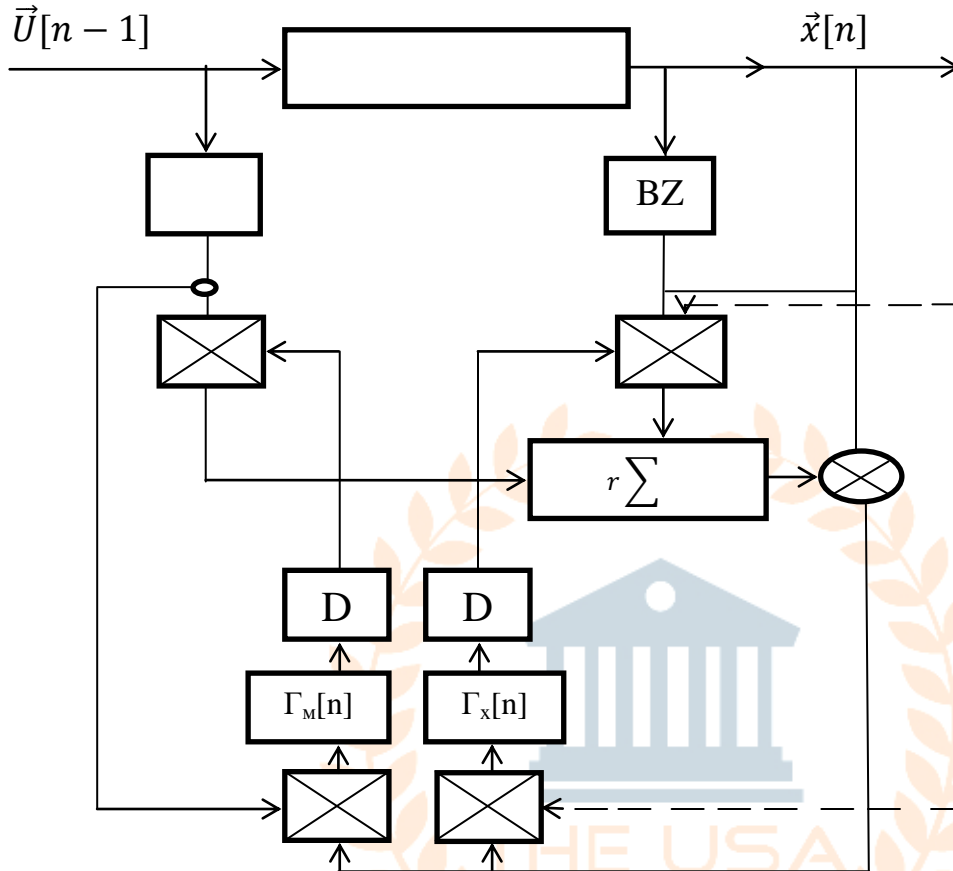

Fig.1. A discrete system that implements an adaptive identification algorithm for multiply connected objects in vector form.

REFERENCES

1. Kholmatov U.S., Shipulin Yu.G. Intelligent discrete systems for monitoring and controlling the parameters of technological processes based on fiber and hollow light guides. Monograph. Tashkent, "Katran" 2018. 140 p.
2. U.S. Kholmatov. On the issue of the transition of automation of individual processes to production complexes. Materials of the conference "Modern problems of innovative development of science, education and production". Andijan-2020, pp. 642-650.
3. Yakovlev S.V., Karelin Ya.A., Laskov Yu.M. "Drainage systems of industrial enterprises". Moscow, Stroyizdat, 1990.
4. Makhmudov M.I. "Formalization of the task of constructing a stochastic simulation model of the wastewater regulation process". Tashkent: Chemical Technology. Control and management. 2011, No. 6.



5. Goodwin G.K., Grebe S.F., Salgado M.E. "Design of control systems". M., Binomial. Laboratory of Knowledge, 2012.
6. O.T.Almataev, U.S.Kholmatov, R.K.Azimov. Optoelectronic converters of the reflective type for automation of liquid and gas calibration flowmeters. BelGUT... - 2014.
7. Kholmatov U.S. Shipulin Yu.G., Norova F.I. Mathematical models of solar photovoltaic installations. "Problems of increasing the efficiency of modern production and energy and resource conservation". Andijan-2018.
8. O.S.Rayimzhanova, O.T.Almataev, Yu.G.Shipulin, U.S.Kholmatov. Reliability of modern optoelectronic elements with fiber and hollow light guides. "Innovation rivozhlanish muammolari: ishlab chikarish, talim, ilm-fan". Andijon, 2017 y.
9. Suxbatillo, R. (2022). DEVELOPMENT OF AN EFFECTIVE DESIGN AND JUSTIFICATION OF THE PARAMETERS OF THE SCREW CONVEYOR FOR THE TRANSPORTATION AND CLEANING OF COTTON. Universum: технические науки, (2-7 (95)), 12-16.
10. Turayev, S., Tuychiyev, X., Sardor, T., Yuldashev, X., & Maxsudov, M. (2021). The importance of modern composite materials in the development of the automotive industry. Asian Journal of Multidimensional Research (AJMR), 10(3), 398-401.

