

ELECTRICAL APPLIANCES AUTOMATION OVER POWER LINE COMMUNICATION

Dr. Lowlesh Nandkishor Yadav
Department of Computer Science and
Engineering,
Tulsiramji Gaikwad Patil College of
Engineering and Technology, Nagpur, India
Lowlesh.yadav@gmail.com

Prof Dr Midhunchakkaravarthy
Department of Computer Science and
Engineering,
Lincoln University College, Petaling Jaya
Malaysia
midhun@lincoln.edu.my

Dr. Dharmesh Dhabliya
Department of Computer Science and
Engineering,
VIIT Pune India
dharmeshdhabliya@gmail.com

Abstract- The widespread reach and deployment of electric distribution lines make them a promising medium for data communication. However, historically, communication over power lines has faced significant challenges, such as instability and reliability issues. Over the years, extensive research and technological advancements have significantly improved the stability of power line communication (PLC), with numerous organizations now focusing on enhancing its safety and efficiency. Despite these improvements, integrating IoT into existing electric distribution infrastructure in residential buildings remains both technically challenging and economically unfeasible at scale. This research proposes a novel approach that combines IoT technology with PLC, aiming to revolutionize the way electric distribution systems function. The idea involves redesigning the current electrical distribution framework to support IoT-enabled appliances with seamless control and monitoring capabilities. The core concept is to develop domestic control nodes capable of communicating internally via the existing power line network. These nodes would enable real-time device management and monitoring without requiring additional communication wiring, making the system more cost-effective and easier to deploy in both new and retrofit installations

Keywords: PLC, HAN, SoC, MAC

I. INTRODUCTION

The concept of utilizing existing infrastructure for data or signal transmission has always been a priority in communication technology. Historically, this approach led to the use of telephone lines for internet connectivity due to the well-established nature of the network at the time. Similarly, power transmission lines, which are already widely deployed globally for industrial and domestic applications, present a compelling opportunity for data communication. By leveraging these lines, it becomes possible to create an efficient and cost-effective communication network. The proposed idea focuses on utilizing power line communication (PLC) to transmit data over existing electrical wiring. This approach eliminates the need for additional cabling to connect individual appliances, simplifying installation while enabling remote control of household devices. With PLC, users can power devices and simultaneously exchange data with them in a half-duplex manner, offering both convenience and functionality. Broadly, PLC is classified into two categories: narrowband PLC and broadband PLC. Narrowband PLC operates at lower frequencies (3–500 kHz), offering longer range (up to several kilometers) and moderate data rates (up to hundreds of kilobits per second). These systems are well-suited for applications like the smart grid and distributed energy systems, such as micro-inverters for solar panels. On the other hand, broadband PLC operates at higher frequencies (1.8–250 MHz), providing high-speed data rates (up to hundreds of megabits per second) but over shorter distances. Broadband PLC has gained traction for last-mile internet distribution and home networking, particularly for multimedia streaming, due to its ability to deliver high data rates without requiring additional wiring. The growing interest in PLC for home and industrial applications is reflected in major market developments, such as acquisitions of key players in the Home Area Networking (HAN) segment. Companies like Atheros (acquiring Intellon), Sigma (acquiring Coppergate), Marvell (acquiring DS2), and Broadcom (acquiring Gige) have all invested heavily in PLC technologies, recognizing its potential for efficient home networking. Another way to classify PLC is based on its application medium: PLC over AC lines and PLC over DC lines. While most current PLC solutions are focused on AC lines, DC line PLC has its own niche applications, including communication over DC buses

in distributed energy systems and vehicle electronics (e.g., airplanes, automobiles, and trains). DC PLC reduces wiring complexity, weight, and cost in such environments. However, for the purpose of this discussion, the focus will remain on narrowband PLC over AC lines.

II. BACKGROUND OF THE SYSTEM

Power Line Communication operates similarly to other communication technologies, where data is modulated at the sender, transmitted through a medium, and demodulated at the receiver. What sets PLC apart is its ability to use existing power lines for data transmission, eliminating the need for additional wiring. Given the ubiquity of power lines, PLC can enable the control and monitoring of nearly all line-powered devices. In the context of communication protocols, the functionality of PLC can be examined through the lens of the 7-layer OSI model. Some PLC chips implement only the physical layer, while others integrate all seven layers. For instance, solutions like Digital Signal Processors (DSPs) can realize the Media Access Control (MAC) layer through software while relying on an external physical (PHY) circuit. Alternatively, optimized System-on-Chip (SoC) solutions, such as the Cypress CY8CPLCXX series, provide a complete PLC stack, including physical, network, and programmable application layers. Before delving into specific applications of PLC, it is important to understand the characteristics of its physical layer, particularly how it is segmented based on data rates. This foundation allows for a clearer analysis of PLC's potential and its suitability for various applications in home automation, energy management, and industrial monitoring systems.

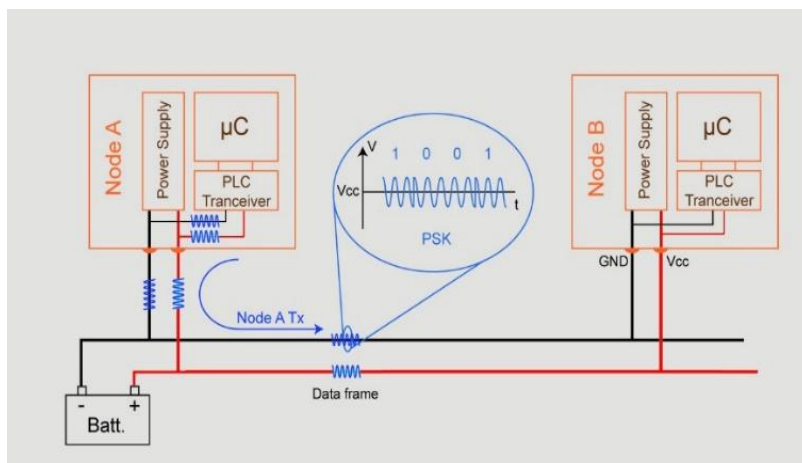

Figure 1.0: Structure of PLC

Modulation Scheme:

Power Line Communication (PLC) systems rely on a variety of modulation schemes to transmit data effectively. Among the commonly used schemes are Orthogonal Frequency Division Multiplexing (OFDM), Binary Phase Shift Keying (BPSK), Frequency Shift Keying (FSK), and Spread-FSK (S-FSK). Additionally, some proprietary schemes, such as Differential Code Shift Keying (DCSK) developed by Yitran, are also in use. These schemes differ significantly in terms of bandwidth efficiency and complexity, as summarized in the comparison below. OFDM, for instance, stands out for its ability to achieve high data rates, though it comes with the trade-off of requiring significant computational power to perform Fast Fourier Transforms (FFT) and Inverse-FFTs (IFFT). This makes it well-suited for applications where high throughput is essential but requires a robust processing unit, such as a Digital Signal Processor (DSP). In contrast, simpler schemes like BPSK and FSK are valued for their robustness and ease of implementation, albeit at the cost of lower data rates. The industry trend leans towards using OFDM combined with PSK modulation (e.g., in G3-PLC and IEEE P1901.2 standards), as these configurations balance efficiency and reliability. While these advanced techniques demand higher computational capacity, simpler schemes like FSK, PSK, and S-FSK can be effectively handled by standard microcontrollers, making them more practical for low-power or cost-sensitive applications.

Standards:

To ensure reliable communication and interoperability across devices, particularly in smart grid and home networking applications, various PLC standards have been established. These standards, governed by organizations such as CENELEC, FCC, ARIB, and the HomePlug Power Alliance, define operational ranges and guidelines for PLC systems. For instance, CENELEC regulates PLC frequencies in Europe, while the FCC oversees them in the United States. A globally unified PLC standard could significantly accelerate the adoption of this technology by eliminating regional discrepancies and simplifying implementation. Among existing standards, G3-PLC has gained recognition for its robust performance, particularly in noisy environments. Meanwhile, the IEEE 1901.2 working group is actively developing a universally accepted standard to further streamline PLC adoption and foster seamless global interoperability.

Frequencies:

The frequency bands allocated for narrowband PLC vary by region, reflecting differences in regulatory frameworks. In Europe, for example, the CENELEC band defines specific frequencies for PLC applications, while in the United States, the FCC regulates its own set of frequencies. Similarly, organizations such as ARIB in Japan and EPRI in North America also define region-specific allocations. These frequency designations ensure that PLC systems operate within permissible ranges, minimizing interference with other communication systems. Standardizing frequency bands globally, however, could enhance the scalability and adoption of PLC by simplifying the deployment process for manufacturers and service providers alike.

This overview highlights the technical and regulatory landscape of PLC, emphasizing the ongoing evolution of modulation techniques, the push for global standards, and the regional considerations for frequency allocation. As the field progresses, advancements in computational efficiency and international standardization are expected to play pivotal roles in shaping the future of PLC technology.

III. LITERATURE SURVEY

Power Line Communication (PLC) has emerged as a viable solution for enabling smart home and building automation. By leveraging existing electrical wiring, PLC offers a cost-effective and scalable alternative to traditional communication systems. This literature review explores recent advancements in PLC technologies, their integration with home automation systems, and their performance in various applications.

Mlynek et al. [1] evaluated the potential of broadband PLC for smart home and building applications, focusing on its ability to provide reliable, high-speed data transfer. Their study highlighted how PLC technology could support the growing demand for smart home devices, emphasizing its scalability and compatibility with other technologies. The authors also noted that challenges such as signal interference and noise could be mitigated through advanced modulation techniques and error correction methods. Costa et al. [6] demonstrated a practical application of PLC through the development of a smart plug prototype. The system allowed real-time monitoring of power consumption, enabling users to manage energy usage more efficiently. This study provided valuable insights into the integration of PLC with IoT devices, showing how it can facilitate the creation of energy-aware smart homes.

Aderibole et al. [2] explored the feasibility of using PLC for low-bandwidth applications such as sensing and control. Their work emphasized the potential of PLC for monitoring and managing distributed systems with minimal data requirements, such as lighting control and HVAC management. The researchers addressed key challenges, including signal attenuation and noise, proposing innovative solutions for enhancing the robustness of PLC in such applications. Similarly, Wanninayake et al. [5] developed a cost-effective, half-duplex PLC system tailored for low-bandwidth home automation. The system demonstrated reliable performance in controlling appliances and sensors, making it a practical

option for residential automation. Their findings underscored the affordability and accessibility of PLC-based solutions for low-complexity automation systems.

Muttillio et al. [4] introduced a low-cost and flexible PLC sensory system for home automation, aimed at improving accessibility for residential users. Their design featured modular components, enabling easy integration with existing devices and infrastructure. The study emphasized the adaptability of PLC to various use cases, including lighting, energy monitoring, and security systems. Visan and Lita [8] proposed a remote control system based on PLC, showcasing its effectiveness in automating household appliances. Their work demonstrated how PLC can provide seamless connectivity in environments where traditional wireless communication faces limitations, such as areas with heavy interference.

Singh et al. [3] examined the convergence of PLC and IoT, highlighting the potential for enhanced automation and monitoring systems. The authors proposed a framework that integrates IoT devices with PLC to achieve real-time control and data analytics. Their work provided a comprehensive overview of the technical and economic advantages of this integration. Varanasi et al. [9] extended this concept by developing a smart edge device utilizing PLC for energy management and appliance control. Their system employed advanced edge computing to process data locally, reducing latency and improving responsiveness. The study also explored how PLC can contribute to energy efficiency in smart homes.

Li et al. [10] conducted a performance evaluation of medium-voltage PLC systems using MIMO-OFDM techniques. Their results demonstrated significant improvements in data throughput and reliability, even in noisy environments. The study provided a foundation for implementing PLC in larger buildings and industrial applications. Benesi et al. [7] explored cable monitoring using broadband PLC, emphasizing its role in ensuring the safety and reliability of power distribution systems. Their work highlighted how PLC can be used for both communication and infrastructure diagnostics, showcasing its versatility in smart grids and buildings.

The reviewed literature underscores the versatility and potential of PLC for enabling smart home and building automation. While studies have demonstrated the practical applications of PLC in energy management, remote control, and monitoring, challenges such as noise interference, signal attenuation, and integration with IoT remain areas of active research. Future advancements, particularly in modulation techniques and edge computing integration, are expected to further enhance the adoption of PLC in home automation. These efforts will pave the way for smarter, more efficient, and sustainable residential and commercial environments.

IV. PROPOSED WORK

Proposed area of research is the fusion of IoT and PLC (Power line communication) where redesigning of complete electric distribution system for connecting IoT based appliances control & monitoring node to take this implementation at next level and may start novel approach in this field. Idea is to design domestic control nodes which will communicate internally over existing power line. This will open wide range of application and functionality enhancement in the field of PLC and IoT. Since the proposed idea is to design a new electric arrangement and the structural changes in the domestic internal electrification line, the figure illustrates (see fig. 2.0) the design structure and the electric arrangement over single line design. Any electrician can refer to this diagram and perform the respective wiring structure.

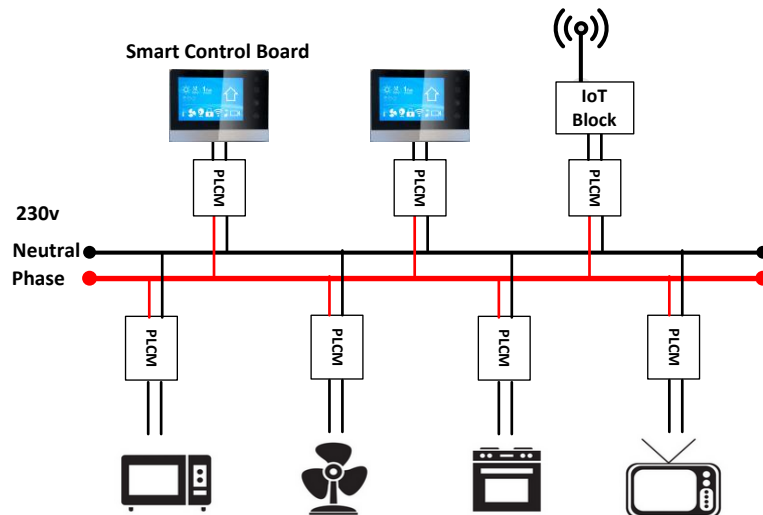

Figure 2.0: Proposed Structural implementation

As a part of research in first phase we will continue with understanding the PLC (power line communication) architecture and its working principle. Preparing the feasibility report of PLC technology over different electric distribution lines and their effects. Along with the feasibility report, we will be writing a review research paper to explore and compare the available research, methodology, and implementation in this area. Here we will find out the possibilities of clubbing IoT technologies with PLC technology.

Next, we will design and implement actual communication between two or multiple entities to transfer low baud rate data over existing electric power lines. This may come up with errors, fluctuations, and data drops due to unstable power supply; hence, we will deploy a power stabilizer and try to find out what could be the best solution for better power line communication. Here, we will implement the dynamic switching board, which may work as a data communication device like transmitter and receiver. After successful and stable PLC communication,

we will design and develop the transceiver modules of communication with multiple IO channels, secure communication, and addressing mechanism for P-2-P communication. Every transceiver will have Rx and Tx mode along with input and output ports. These ports will let the system read sensor information or control the appliances, and the addressing scheme will allow the system. Finally, we will implement and test a real-life scenario by restructuring the home electric distribution over a single pair of wires at multiple points in different rooms in a home. Figure 1 describes the proposed structural implementation where smart control boards are responsible to control all the appliances over power line addressable communication protocol. This communication will be prepared to have individual identity or a unique address to each node.

These addresses will be used to send signals to specific nodes. At the same time, the PLCM module connected to the IoT block will let the user control and monitor the appliance with its current status over the internet using web or mobile applications. This is one of the main goals of the research area: redesigning the domestic electric distribution line method from multiple or individual phase to every home appliance using a parallel wire method to a single wire or serial wiring method. This will help in saving more money spent on wiring and reduce the chances of fire or short circuit in wiring over the period. Next is to deploy the PLC-based control node at different locations and test the inter-communication and control mechanism of every node.

V. PROPOSED METHODOLOGY

Typically, electric customers receive an input line till the electric meter from the electricity distribution supply chain. Depending upon the rooms or the distribution required, electrical creates multiple points to every level in domestic use, for example, bedroom, hall, kitchen, and etc. upon successful laying of wire

electrical lay wire from switch board to individual appliances. This whole process required multiple loop or running of wires from switch board to every appliances. This surely waste or require long wire laying which may become difficult for maintenance in future.

Another problem or dis-comfort in big home or multi store buildings is controlling or operating appliance from physical location of switch board. User can't control appliance of any room from different room or the floor. User need centralized control or the remote control to have this features. Proposed design resolve the mentioned issue and also provide ease of accessing multiple room appliances from central or any location in premises. As illustrated in diagram 2.0 at every point along with home appliances, a PLCM module (proposed idea) will be connected and this module will allow communication between all electric appliances. In this network, one or more appliances will be smart switchboard which will allow user to control any electric appliance from any location. This central control board will send a special piece of information to individual electric appliance and receiving electric appliance control its defined operations. Proposed PLCM modem having primarily three part where 1). PLC communication modem 2). Device switching relay board 3). Microcontroller based control system. Combination of these three component will form a module which allow connect all electric appliance on single line and hence this single line entire electric appliance control system becomes a novel idea or the process to achieve targeted goal . Proposed methodology will be divided in phases where first we will develop the IoT based master node which will internally communicate with all deployed control nodes. This master node also having functionality to communicate with cloud server over network protocol and let the IoT clients or user communicate with and control the internal nodes or receive data from. Here after all testing, we will redesign the node as a final marketable packaged product and file design patent for the device. Finally developing cloud-based SaaS model to develop web platform for controlling, monitoring and analyze the individual node performance over the period.

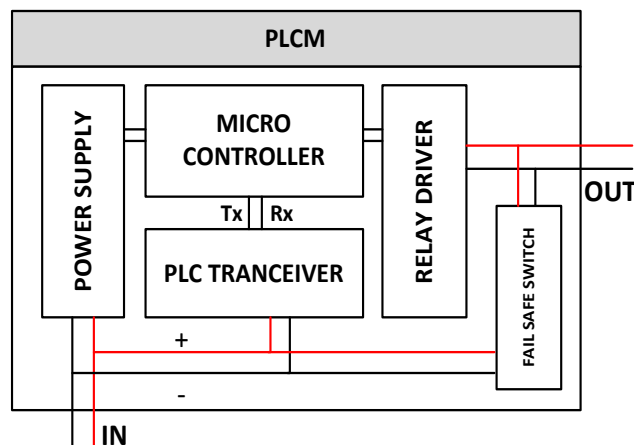

Figure 3.0: PLCM Block diagram

Figure 2 describes the PLCM internal blocks where main power line will be utilized for communication at the same time to power up the PLCM node internally and to power up the appliances. PLC transceiver module will be used to send and receive the data and transfer it over serial port of the module. Serial port of PLC module will be interfaced with microcontroller to process the data as per the definition and microcontroller will be also responsible for to drive the relay board in order to control the appliances on signals. In case of failure of communication every node will be having fail-safe backup switch to control the appliances manually. Efficiency of communication and protocols will lead to right functioning of the system. Proposed Power Line Communication Module and its internal electric blocks are described (See fig. 3.0).

IN Line: These two illustrated red and black lines are the electric input line to from electric board to every PLCM. These line are input to the PLCM module and these will the source of power to the PLCM also along with the connected electric appliances.

OUT Load: As mentioned [201] input line to the PLCM will be having output terminal to connect electric devices. In basic sense the PLCM will be connected in between input electric line and the electric appliance to be controlled.

PLC Transceiver: All the mentioned communication will be performed and data exchange done using the PLC transceiver module. This will be responsible for data or message passing between different network entities.

Microcontroller: Central microcontroller to control the logic functionality and the relay board control command execution upon received communication or the message from PLC transceiver.

Rx,TX Lines: PLC transceiver and the microcontroller are connected to each other using these serial or USART communication line. These lines having two line one for transmission (Tx) and other for receiving (Rx).

Realy Driver:To control the electric appliance PLCM module utilized electric switching mechanism and this mechanism provided by relay switching board. This driver will control electric line to the electric appliance.

Power Supply: to power up all electric component inside the PLCM this step down power supply will be used.

Fail Safe Switch: In case of failure of complete PLCM module the system will be having failsafe electric appliance control mechanical switch. This switch will allow devices to control manually.

VI. CONCLUSION

Tests in PLC have been carried out in 20 countries in around 1500 residences. The mapping of results has been extremely positive and forecasts a great demand for the system. Power line communication technology is definitely an exciting alternative to connect internet via phone and modem. Though this technology is not commercially available yet, it should be available over other broadband technologies due to relatively low cost of its local loop. Moreover, its high speed will provide internet access, local phone, and long distance service to customers.

Reference

1. Mlynek, P., Rusz, M., Benesl, L., Slacik, J., & Musil, P. (2021). Possibilities of Broadband Power Line Communications for Smart Home and Smart Building Applications. *Sensors (Basel, Switzerland)*, 21. <https://doi.org/10.3390/s21010240>.
2. Aderibole, A., Saathoff, E., Kircher, K., Leeb, S., & Norford, L. (2022). Power Line Communication for Low-Bandwidth Control and Sensing. *IEEE Transactions on Power Delivery*, 37, 2172-2181. <https://doi.org/10.1109/tpwr.2021.3106585>.
3. Singh, R., Gehlot, A., Thakur, A., Akram, S., & Das, P. (2020). Automation focused on Power line Communications and the Internet of Things. *International Journal of Innovative Technology and Exploring Engineering*. <https://doi.org/10.35940/ijtee.g5902.059720>.
4. Muttillio, M., Muttillio, V., Pomante, L., & Pantoli, L. (2020). A Low Cost and Flexible Power Line Communication Sensory System for Home Automation. *2020 IEEE International Workshop on Metrology for Industry 4.0 & IoT*, 191-196. <https://doi.org/10.1109/MetroInd4.0IoT48571.2020.9138191>.
5. Wanninayake, W., Kumarasiri, B., Dharmaweera, M., & Pilanawithana, B. (2021). Development of a Cost-effective Half-Duplex Power Line Communication System for Low Bandwidth Home Automation Applications. *2021 3rd International Conference on Electrical Engineering (EECon)*, 62-68. <https://doi.org/10.1109/EECon52960.2021.9580877>.

6. Costa, W., Santos, W., Rocha, H., Segatto, M., & Silva, J. (2021). Power Line Communication based SmartPlug Prototype for Power Consumption Monitoring in Smart Homes. *IEEE Latin America Transactions*, 19, 1849-1857. <https://doi.org/10.1109/TLA.2021.9475618>.
7. Benesl, L., Mlynek, P., Ptacek, M., Vycital, V., Misurec, J., Slacik, J., Rusz, M., & Musil, P. (2022). Cable Monitoring Using Broadband Power Line Communication. *Sensors (Basel, Switzerland)*, 22. <https://doi.org/10.3390/s22083019>.
8. Visan, D., & Lita, A. (2021). Remote Control System Based on Power Line Communication. 2021 IEEE 27th International Symposium for Design and Technology in Electronic Packaging (SIITME), 301-304. <https://doi.org/10.1109/SIITME53254.2021.9663427>.
9. Varanasi, L., Member, I., Member, I., Karri, K., & Rao, A. (2024). Smart Edge Device Utilizing Power Line Communication for Energy Management and Control of Electrical Appliances. *IEEE Access*, 12, 37207-37218. <https://doi.org/10.1109/ACCESS.2024.3373009>.
10. Li, Y., Zhang, M., Zhu, W., Cheng, M., Zhou, C., & Wu, Y. (2020). Performance evaluation for medium voltage MIMO-OFDM power line communication system. *China Communications*, 17, 151-162. <https://doi.org/10.23919/JCC.2020.01.012>.