

## Mould Making, Matrix Fitting, and Hand Casting

*Stan Nelson*

Joseph Moxon, the author of *Mechanick Exercises on the Whole Art of Printing*, arranged his essays on typefounding in a very particular manner. He began with the art of letter cutting but before moving on to matrix justification and type casting, Moxon stopped to discuss the making of the mould. The reason was simply that matrices cannot be justified or type cast without it. As Theodore DeVinne so clearly states in *The Invention of Printing* (1878), 'In this type-mould we find the key to the invention of typography. It is not the press, nor the types, but the type-mould that must be accepted as the origin and symbol of the art. He was the inventor of typography, and the founder of modern printing, who made the first adjustable type-mould.' It was the type mould that made printing from movable type a practical and economical process.

Henk Drost of Enschedé has described how a punch is cut, so I will go on to describe how the punch is used to strike a matrix, how the matrix is justified, and how types are cast. But first, like Moxon, we will take a detour to see how that most important mould can be made.

Mould Making In its elemental form, the type mould is made up of two 'L' shaped pieces. During casting these fit closely against each other. By adjusting their position, they can be made to form either a wide or a narrow cavity. Because this cavity changes only in width, all the letters cast in the mould have the same exact body and height.

While authors in the past have speculated about the construction of early type moulds, the oldest surviving type mould, discovered in the collection of the Plantin-Moretus Museum, Antwerp, is quite similar in its construction to moulds used commercially for type production as late as the mid-nineteenth century. This early mould falls into the category of 'Flemish' mould which is one of two major divisions of type mould construction, the other being the 'French' style. The Flemish mould has all of its various pieces fastened to the 'carriage', but the many parts of the French mould are fixed to 'base plates'. There are many variations on these two approaches, but so far I have chosen to make French-style moulds. It is this form of mould that I will now describe in more detail.

*Figure 1*  
The bottom half of a 20 point type mould from the author's shop.

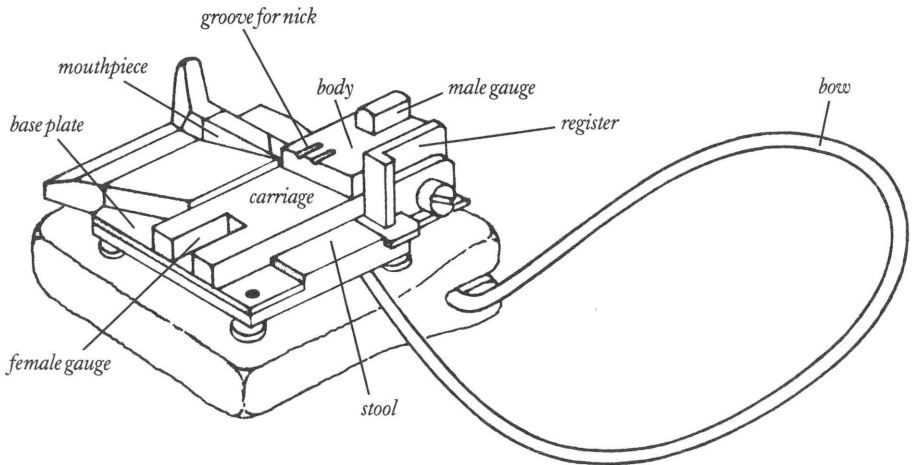

The 'L' portions of each half of the mould are made up of two carriages and body pieces. These four pieces, when joined properly, create the cavity which forms the body of the type. A 'mouthpiece' is provided to serve as a funnel to guide type metal into the mould, and it also forms the feet of the type. The 'stool' and two 'registers' position the matrix beneath the mould so that the face of the type will be cast in the exact position required (relative to the body). These various parts can be seen in Figure 1. By thoroughly understanding how the mould works, how it can be assembled and which dimensions are important, almost any craftsman can make a usable mould.

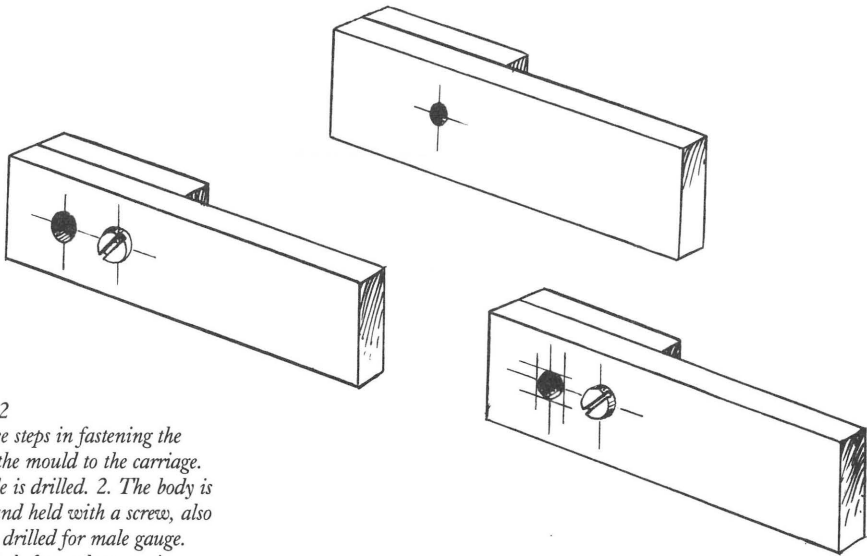

*Figure 2*

*The three steps in fastening the body of the mould to the carriage.*

- 1. A hole is drilled.*
- 2. The body is tapped and held with a screw, also a hole is drilled for male gauge.*
- 3. The hole for male gauge is marked out for filing square.*

The carriages and body pieces require the greatest attention to accuracy when building a mould. These four chunks of metal have to be sawn, filed (or milled) and lapped (or ground) to very precise dimensions in order to establish the height-to-shoulder and body size of the mould. All four pieces must be exactly the same height. They must also be carefully squared. The body pieces have to be the exact thickness of the type to be cast and the inside end of each body piece has to be perfectly square. Once these two pairs have exactly the correct dimension, they are fixed together with screws as shown in the drawing in Figure 2. It is very important that the body and carriage be clamped together when they are drilled to keep them in the proper relationship to each other.

The carriage and body pieces are held to a 'base plate' partly by a 'male gauge' and also by a screw (Figure 3). The 'male gauge' is square in cross-section, requiring that a square hole be made through the body, carriage, and base plate. This is done by drilling a hole and then filing the corners out. Once the male gauge and screws have fixed the carriage/body unit to the base plate, a slot is cut in the other end of the carriage to fit the male gauge. This slot is the female gauge. It serves to create a close sliding fit of the mould halves which helps insure accurately cast types. After fitting these halves to each other, the craftsman can consider the mouthpiece.

*Figure 3*

*The male gauge is fitted and holds the body, carriage and base plate together.*

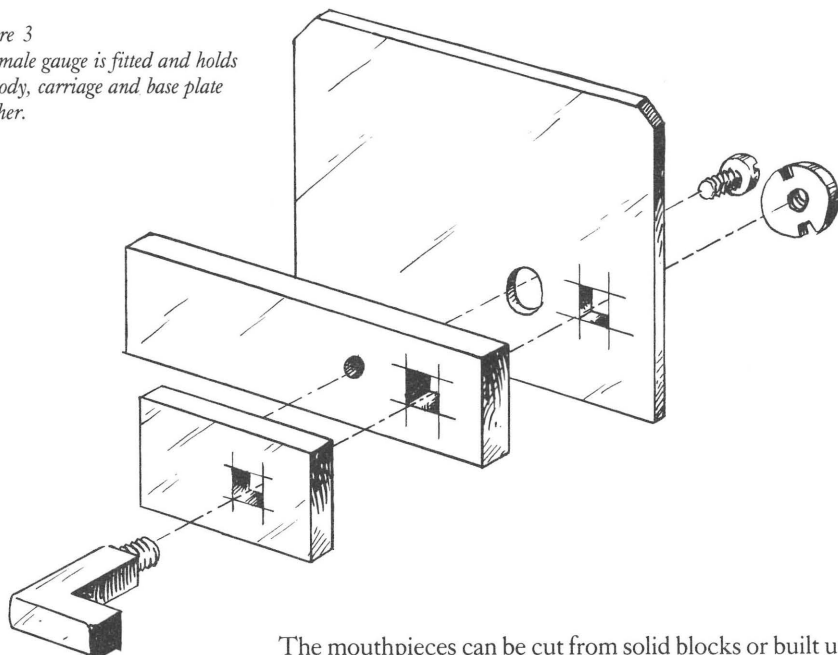

The mouthpieces can be cut from solid blocks or built up from separate pieces (Figure 4). Smaller moulds are best made with a single piece, but large ones can make good use of the two piece construction. In either case, the opening in the 'throat' of the mouthpiece, where the metal enters the body cavity, should be about one-third of the body being cast. The volume of the jet formed by the mouthpiece should not be too great.

*Figure 4*

*An end view of the mould and a perspective view of one form of mouthpiece.*

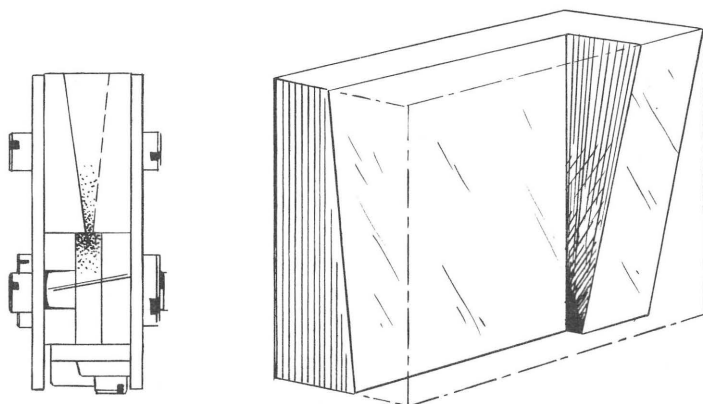

A large jet is easy to fill but it uses up a lot of molten metal. Thus the mould heats too quickly, and the pot empties sooner. For both reasons, it slows the caster. Of course the mouthpiece should be large enough to pour metal in freely. It is helpful to look at examples of original moulds when planning the mouthpiece.

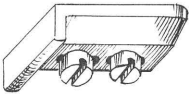
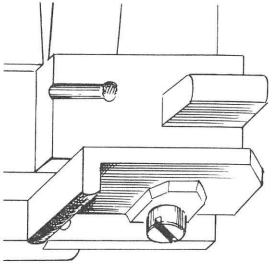

Figure 5  
The register in two forms.

The mouthpiece should fit closely but not interfere with the closing of the mould, which would prevent the types from being cast to the correct dimension. A slightly oversized mouthpiece may not be obvious, but the types cast will not be parallel. A noticeably undersized mouthpiece makes the mould liable to 'rock' and will also encourage type to be out of parallel or 'unsquare'.

The registers come next (Figure 5). The cheeks of the register are square to the mould and close firmly upon the matrix when casting. The registers determine the 'set width' of the various letters since each matrix is made wider or narrower according to the letter it contains. The registers are fitted to the carriages with from one to three screws. They position the matrix laterally below the mould and once set, they do not need to be moved very often. Adjustment may be needed when casting a heavily kerned letter such as 'Q', so it is best that the registers be movable.

Now the mould is really shaping up. It has the carriages, bodies, mouthpieces and registers in place, and can be used as is; but, to be really complete, several more items are needed (Figure 6). Although the base plate can serve as a 'stool' or abutment for the head of the matrix, it is best to have a separate stool fitted since this allows adjustment for wear and for a change from one set of matrices to another when alignment differs. Stools can be made in various ways that are very adjustable or very simple.

Insulators are needed in order to prevent the typefounder from burning his hands. These are held to the base plate by a screw and brass nut. The screw is often riveted to the base plate and the nut is either slotted or has notches cut in its edge to allow it to be turned with a special wrench. A large spring or 'bow' is mounted to the 'bottom half' of the mould. (The bottom half rests in the left hand and has the stool fixed to it.) This bow can have various shapes but usually forms a large circle with its point resting just below the mould where the matrix rests (Figure 7). The bow is a very noticeable feature of the mould. It often elicits a question regarding its

*Figure 6*  
*The stool in four forms and a view*  
*of how the insulator is held to the*  
*base plate.*

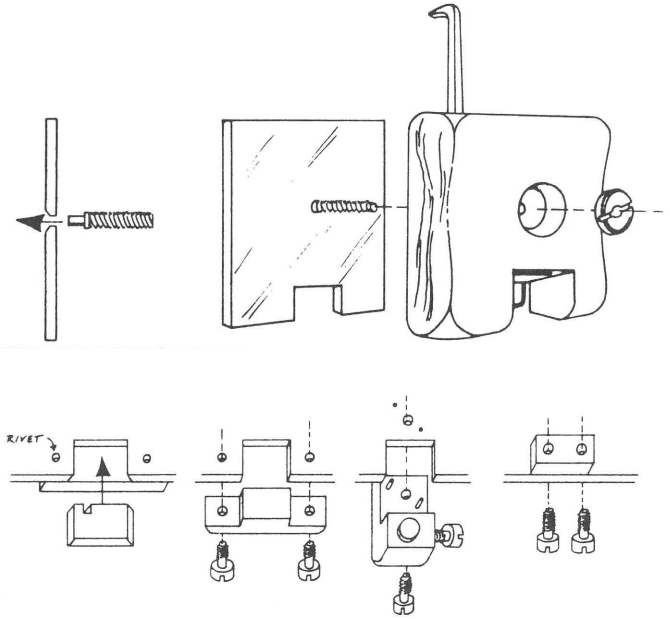

*Figure 7*  
*The lower left shows a view of the*  
*matrix supported by the gimlet and*  
*the jobbet.*

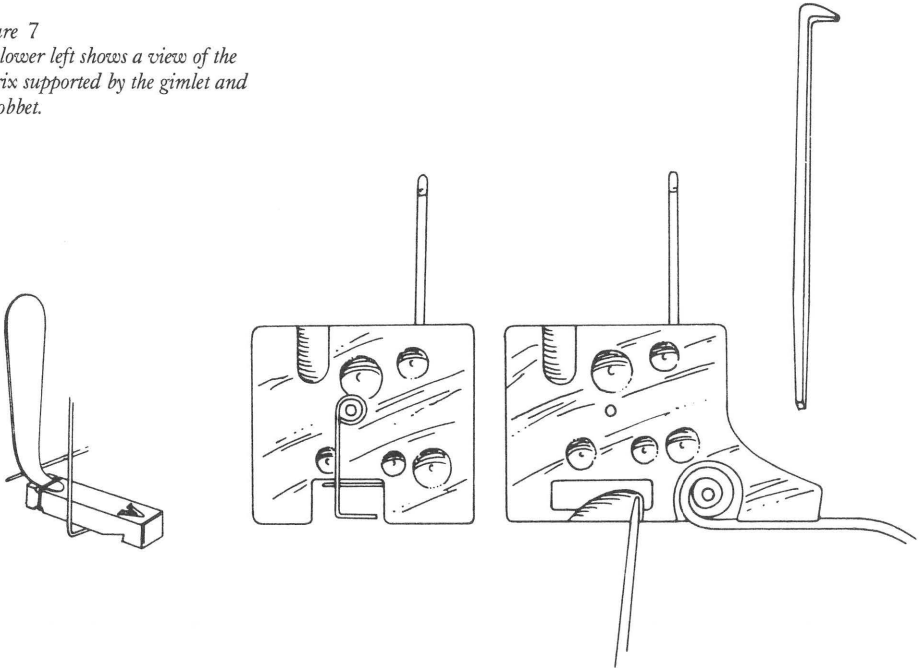

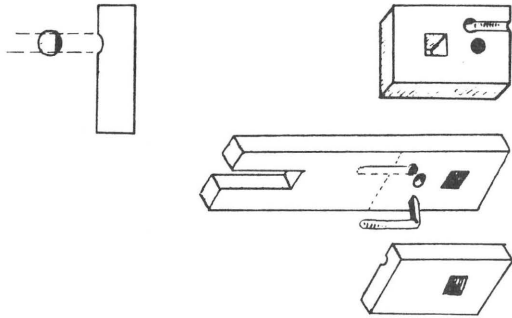

Figure 8

*The nick wire fits into the mould. The end view emphasizes that the nick is not quite half the diameter of the wire. (If it were, the types would not come out of the mould so easily.)*

purpose which is quite simply to hold the matrix in position while casting. I should mention that some moulds had a 'jobbet' and 'gallows', which are wires that help support the matrix beneath the mould during casting in order to increase production.

I have left out one important feature of the mould which could easily have been added earlier. It is my habit, however, to add this item when the mould is nearly done. I am referring to the 'nick wire' which is needed to form the identifying nick in the cast type (Figure 8). It is simply a piece of wire, filed flat on one side a bit more than halfway. The nick is fitted to the 'top half' of the mould. It is held in place by engraving a slot in the back of the body piece in the top half. A corresponding slot is engraved in the bottom half to receive the nick wire when the mould is closed. Some moulds had several nicks. Frequently hand moulds had only one. Usually additional nicks indicated that more than one mould of a given size was in the foundry or that it was a bastard (or odd sized) body.

After all of this work one step remains before the mould is ready to be used. A number of types are cast and measured to determine whether they are accurate. If any error is detected it must be corrected before type is cast. This is called justifying the mould and might involve hours of careful work until the types cast are perfectly square.

That just about wraps up the making of a French-style hand mould. Clearly it is a business that requires patience and some skill with tools. A machine shop is also usefull. Still, you can make a mould with a saw and files. It's all a matter of will.

## Matrix Fitting

Matrix fitting represents one of the most crucial steps in preparing a new font for casting. It is probably as important as punch cutting since a poorly cut design, well fitted, is useable, whereas a poorly fitted font of matrices will render a well-cut design useless. Matrices *are* the heart and soul of a foundry. They were carefully stored, and if lost by fire, meant the absolute loss of the foundry. Moulds and other hardware could always be replaced, but matrices struck from punches were in many cases unique. Let's explore what work goes into the preparation of matrices by hand.

Before any other work is begun, the punches should be examined to see whether they are all clean, free of cracks and are straight. If they are warped, small bits of gummed paper may be glued at the proper points to bring the face parallel to the surface of the copper into which it will be struck. If a punch is cracked badly, it may be useless, but if the crack is not too serious it may serve. The various widths of the letters are noted to determine the widths and quantity of copper blanks that will be needed to strike all of the punches.

Figure 9

*A striking: This press for driving matrices is in the collection of the St. Bride Printing Library, St. Bride Institute. The photograph was taken with the kind permission of Mr. James Mosley.*

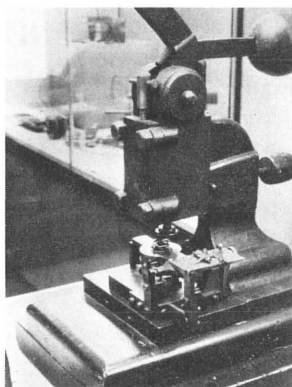

Pure copper blanks must be carefully prepared before striking. The sides of the copper blanks are filed square to the face. Then the face is smoothed and polished. If the design to be struck is large, the copper might require annealing by being heated and quenched in water. This will, however, cause the surface of the copper blank to 'cave in' when the matrix is struck, requiring a deep strike and causing a lot of distortion. For this reason, annealing is best avoided if possible. One-quarter inch thick copper was common, but I use strips that are three-eighths of an inch thick. This is cut to the desired lengths. There is more substance to the thicker copper which reduces distortion during striking, and it is a little easier on the punch. Once the copper blanks are ready it is time to begin striking the punches.

Three fingers and a hammer represent the oldest method of holding punches while striking them into copper. Fournier Le Jeune, writing in the mid-eighteenth century, recommended this method. Elaborate striking fixtures were, however, used as early as the 1680's. Since a 'matrix well struck is half justified', and the greatest risk for the punch occurs during striking, any tool that lessens the chance of breakage and helps ensure a 'true' strike is worth the trouble of making it.

Assuming a fixture will be used, the punch is clamped over the polished matrix blank and the two are adjusted relative to each other using guide lines marked on the face of the copper to help determine the exact position. With everything clamped in place, the punch is either beaten into the copper blank with a hammer or the fixture is positioned in a 'striking', which is a large press (Figure 9). These 'striking's can be set to powerfully push the punch to exact depths and they are a great improvement over the hammer since they are more precise and are less liable to break the punch.

The punch is driven into the copper a bit deeper than the final depth required to allow for 'fitting' and the fixture is disassembled. After rubbing off the bulges of copper produced by striking, the depth of the drive is measured with a needle gauge (Figure 10). The overall depth should be sufficient, and any irregularity in depth is observed. Before beginning to alter the depth of the strike, casts are made to double check the squareness of the face. In most cases, one portion of the strike is deeper than another. This fault is noted and that portion of the strike which is too deep is filed away. If

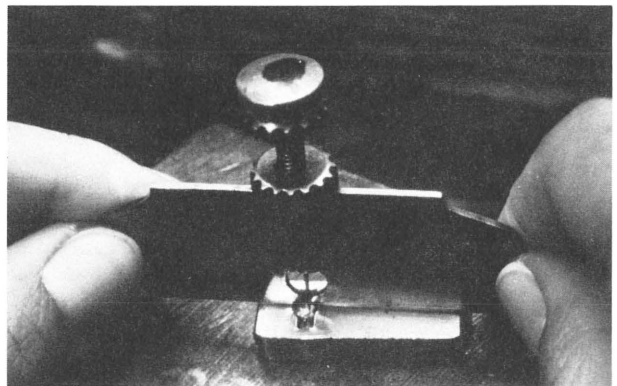

*Figure 10*  
A needle gauge in use. The needle gauge measures the depth of the strike into the matrix and helps determine if the drive is level.

the discrepancy is very great, it may be best to re-strike. Still, careful filing can be quite effective. Once the face of the strike has been adjusted, the sides must be checked with the tri-square and made true to the face. If the sides are not square, there will be a tendency for the registers of the mould to force the matrix out of position. This results in inaccurate casts that will be misleading and may complicate the task of fitting. Also, chips of metal below the mould can throw off a cast and cause one to file away the matrix where it is not needed, if the fault in casting is not noticed.

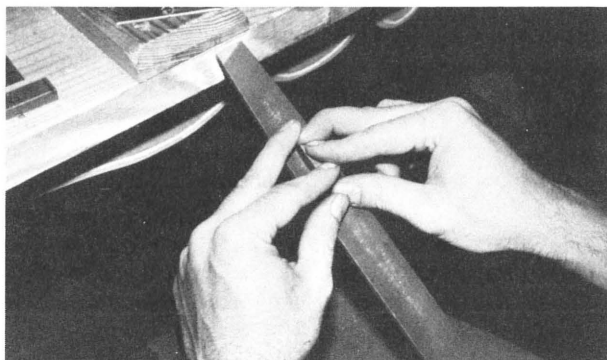

*Figure 11*  
*Rubbing a matrix on a file during*  
*the fitting of the matrix.*

By steady, careful filing, the depth of the matrix is made even and is brought to the exact dimension needed. A height-to-paper gauge is used to check the height. Much of the filing is done by bracing the file between the stomach and the work bench and rubbing the matrix face down on the file (Figure 11). Very small amounts of metal are carefully removed, depending on where the fingers are placed and how hard one presses on the matrix. It is easy to round off the face of the matrix by careless filing, so care is needed. Once the depth is correct, it is time to adjust the alignment of the letter. (In fact, I do preliminary alignment when I am adjusting the depth of drive.) Final alignment is determined by placing trial casts between standard letters such as the capital 'H' or lower case 'x'. I use a lining stick and straight edge but an alignment gauge is better. This tool has a built in straight edge and a micrometer screw adjustment to allow very fine measurements. Some letters such as 'o', 'e', 'v', or 'w' require special care since they are made a trifle larger than 'm' or 'x'.

Adjusting the verticality of the letters and the exact 'set width' for each letter represents the toughest part of matrix fitting. Where fitting the depth of drive is a purely mechanical operation and adjusting the alignment is nearly so, making the letters seem vertical and adjusting the set widths is a subtle operation and makes the greatest difference between really well fitted letters and those that are less so. There are many optical illusions to consider when fitting matrices. Letters such as 'b' and 'd' must be made to lean a little, so as to seem upright. Some letters must be fitted closer together than others so that they will all seem evenly spaced. The ideal space between letters is thought to be the space within the strokes of the lower case 'n' or 'm'. (Fournier's comments on fitting are excellent, and an article by Joseph Blumenthal in *The Dolphin*, Vol. II, p. 71, should be referred to.)

This single subject of 'fitting' is sufficient for a monograph of its own. I will end this portion with the comment that this is truly where hand-set foundry types are superior to other forms of type setting. The founder arrived at the optimum fitting of his book fonts after months of work by craftsmen who had spent their entire careers learning their skills. Book fonts were well fitted when cast and sold. The printer could not mishandle them very much. Admittedly there were always a few awkward combinations such as 'WA' and 'LA', but good fitting and a knowledgeable compositor could deal with those well established situations. Today, despite the potential for kerning and mortising type, actual typesetting practice is less than perfect. The compositor can tighten up a line or spread it out to suit himself. If a column is narrow, the type is made to fit. So much for good letter fitting!

1. *A rough strike or matrix.*
2. *The strike filed smooth and square for casting.*
3. *It may be necessary to protect part of the matrix from being filed away by raising its edge with small dents (upper left) so that the file cuts away only undesired parts of the matrix (lower right) to achieve squareness.*
4. *A final fitted matrix.*

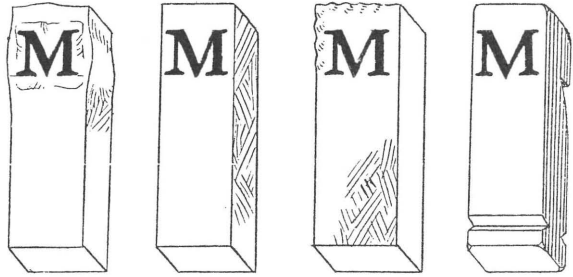

With a matrix fitted for depth, alignment, uprightness, and set, all that is left is to cut a notch for the bow and leather grooves (Figure 12). These small details vary according to the period, locale, and maker. With the matrices carefully finished and stored in a drawer or box, one can begin using them for casting.

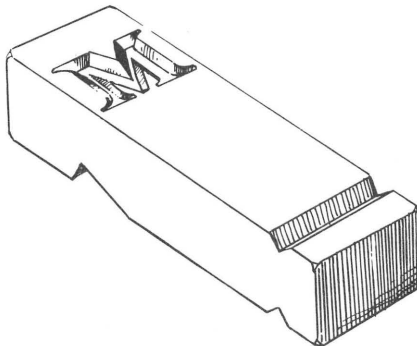

Figure 12  
*A matrix for a hand mould.*

### Casting Type with a Handmould

The primary goal of the typefounder is to produce clean, sharp faces correctly aligned on accurate bodies. When casting type by hand, the typecaster must adjust several factors in order to satisfy this goal. Metal temperature, manner of pouring, percentage of metals in the alloy, type size, set width, and type design all influence the quality and ease of casting.



*Tools used in casting type.*

Adjusting the temperature of the metal is the simplest step towards better type. It is best to use the lowest temperature of metal that will work. This will reduce shrinkage and seems to minimize air bubbles. Small type bodies require hotter metal than large ones, so gradually raise the temperature until casting becomes easier.

While raising the temperature of the metal it is best to experiment with the 'shake' given to the mould when the metal is poured in. This unusual motion, consisting of a sudden, upward jerk at the instant of pouring, helps force the metal into the face of the matrix. Both the force and angle of the shake are varied for different individual letters. The shake is the essential skill developed by a caster over years of practice, and it has a lot to do with his success.

In stubborn cases it becomes necessary to alter the proportions of the tin, lead, and antimony that make up typemetal. Metal containing more tin is less hard but more free flowing, so stubborn letters or characters with large kerns may 'come-up' better in softer metal. I should add that the composition of the metal is also varied according to the size of type being cast. Small types are best cast in hard metal but larger bodies must be made of softer metal. This

is largely due to the rates at which the mixtures solidify but wearability is also a consideration. Hard metal solidifies more rapidly than soft metal, but it wears better.

Regardless of size, the set width of types affects casting. Very narrow sets can be hard to cast but wide sets are always harder to cast. The capital letters 'M' and 'W' are usually the worst. Coating the mould with soot from a lamp or candle is a great help in stubborn cases, especially with small bodies.

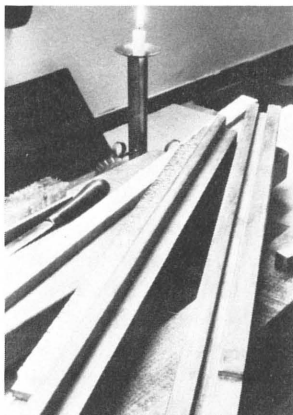

*A dressing rod. Individual pieces of cast types are placed upside down in a row on the rod and trimmed at the foot to insure an even height for consistent printing.*

Finally, the type design is a major factor in determining whether types are easy or difficult to cast. Highly ornamental or shaded letters are sometimes impossible to cast by hand. Very bold, 'fat face' designs can be quite difficult to cast cleanly. Some characters with thin serifs can present problems since the fine details can resist 'coming-up'.

In addition to the essential task of casting a clean face, the typefounder must continually watch that the letters he makes are cast with the proper set width and alignment. The bodies of hand cast type must be accurate as to size and parallelness, but small wrinkles and air bubbles are common and do not present a problem, unless the voids are large.

After the types are cast they go through several more stages in the process of 'dressing', or finishing. The jet, formed in the mouthpiece of the mould, is broken off, the letter rubbed on two sides on a flat stone, and then the rubbed sorts are composed on 'setting sticks' which are fairly long wooden sticks made to support a long line of type. When the stick is full, the line of rubbed types is scraped smooth on the remaining sides and then is moved into the dressing block where the feet of the types are grooved to trim away the rough spot where the jet was removed. After having the feet plowed, the types are ready for printing unless the particular letters have overhanging kerns which require special trimming. Types cast in the nineteenth century and earlier had their shoulders 'bearded' or trimmed so that they would not print accidentally. In the twentieth century this procedure has been omitted since it is no longer necessary.

With the type dressed and ready for use, this brief account of matrix fitting and type casting is finished. I wish that there were space enough to give all of the particulars of this subject, but I believe that you should at least now have

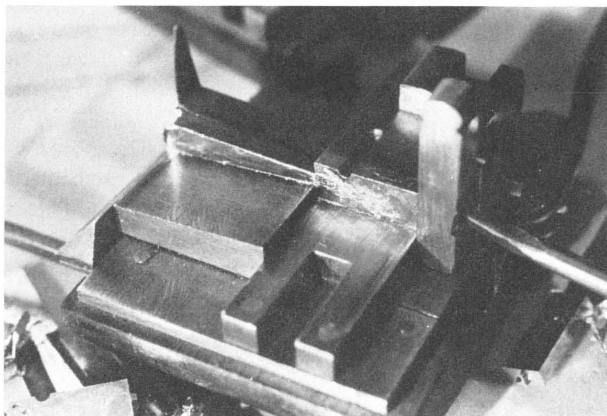

*A close-up of the author's 24 point mould.*

a clear understanding of all the work that goes into producing type with early hand methods. If you want to learn more about this subject, I recommend that you refer to Joseph Moxon's *Mechanick Exercises on the Whole Art of Printing* and 'Fournier on Typefounding' which is the text of the *Manuel Typographique* translated by the late Harry Carter.

*The author casting type.*

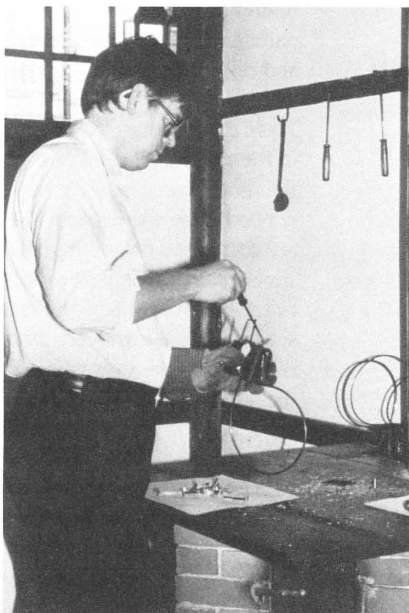



*The printer's mark of The Hackiana Press. Leyden, 1671.*



The printer's mark of Antoine De Harsy. Lyon, 1550.