

## Tribological Properties of Nano-MMT/In Lubricant Additive on Steel-bronze Tribo-pair

Yang Cao<sup>a</sup>, Taoyue Yang<sup>\*b</sup>, Dabin Zhang<sup>a</sup>, Quan Wang<sup>c</sup>, Xiaohui Guo<sup>c</sup>

<sup>a</sup> College of Mechanical Engineering, Guizhou University, Guiyang, 550025, P.R.China,

<sup>b</sup> Guizhou Vocational Technical Institute, Guiyang, 550023, P.R.China,

<sup>c</sup> Guangxi ZhongYan Ltd, Nanning Guangxi, 530001, P.R.China,  
 29050672@qq.com

In order to obtain the tribological properties of nano-montmorillonite (MMT) /In lubricant additive on steel-bronze tribo-pair. 1:1 MMT/In composite nano-powders were prepared by nano-MMT and nano-In modified with coupling agent KH550, and the nano-MMT/In lubricating oil dispersion system was prepared by 150 N base oil containing 3 mass fraction of nano-MMT/In composite powders, and then took the dispersion effect by TEM. The anti-wear and friction-reducing behaviors of that lubricating oil dispersion system were observed on the MMU-10G abrasive-wear tester with steel-bronze tribo-pair, the morphology and the element of the worn surfaces were analyzed by SEM and EDX. The results showed that the modified nano-MMT/In had the good dispersion in the system; compare with the one in base oil system, the average friction coefficient of sample of steel-bronze tribo-pair in nano-MMT/In additive lubricating oil system had declined by 22.65 %, and the total wear mass loss had declined by 47.62 %; The surface of sample after friction had created the self-repairing film that contain the characteristic element of MMT and In, that phenomenon was caused by the interaction of nano-MMT and nano-In.

### 1. Introduction

It has received considerable achievements (Qiao Y L, 2005) to try to apply nano particles as the lubricant additives, for example, the relevant researches on adding nano soft metal, nano oxide, nano rare earth compound, nano layered inorganic substance, nano diamond, etc into lubricant, to improve the antifriction and abrasion resistance performance of the lubrication system. Many researchers has proved that material, such as nano Cu (Gao X L, Wu L, Li J, et al, 2010), nano Ag (Li J, Zhang S M, Wu Z S et al, 2006), nano CaCO<sub>3</sub> (Gu Z M, Gu C X, Fan S Q, 2007), nano SiO<sub>3</sub> (Shao X, Tian N J, Liu W M, et al, 2002), and nano diamond (Zhang J X, Liu K, Hu X G, 2002), etc, played a role of improving the lubricant system performance, by studying of adding such single phase nano material into lubricants. Some scholars have studied the composite nano additives, and have better comprehensive tribological properties. Dong Ling (Dong L, Chen G X, Fang J H et al, 2009) made Mg-Sn model compound nano additives, and proved its excellent antifriction and abrasion resistance performance as well as its self-repairing capacity. Yang Lv, Wu Xuemei and Zhou Yuangkang applied nano palygorskite/Ag (Cu) of hard and soft phase composition as the lubricant additives, and got the results that the friction coefficient and abrasion loss of such lubrication system was obviously lower than that with single palygorskite or single Ag (Cu) (Wu X M, Zhou Y K, Yang L, 2012), and meanwhile there was self-repairing film formed on the friction surface (Yang L, Zhou Y K, Li Y et al. 2012).

In mechanical equipment, steel - Bronze friction pair is more common, such as worm gear, screw nut pair and hydraulic components, etc. Steel bronze friction pair has the advantages of reducing friction, anti - wear and anti - bonding ability (Kong X M, Zhang S, Wen S Z, 1997), but need to be lubricated. And the better performance lubrication system can further improve the tribological properties of steel bronze friction pair. This article will study on the tribology performance of nano MMT/In composite nano material based on previous studies, as the lubricant additives, to steel-bronze friction pair, and analyze its tribology performance improvement and film-forming mechanism.

## 2. Experiment

### 2.1 Experiment materials and equipments

Material and reagents include: nano Montmorillonite (Zhejiang Fenghong Clay Chemicals Co., Ltd); nano Indium (Shanghai Chao Er Nano Technology Co., Ltd); KH550 silane coupling agent (chemically pure, Nanjing Shuguang Chemical plant); base lubricants (150N, Jiangsu Kunshan); absolute ethyl alcohol (chemically pure, commercially available).

Instruments and equipments include: MMU-10G friction-abrasion testing machine; IRAffinity-1 Fourier transform infrared spectrometer; Winner801 laser particle size analyzer; JSM-6490LV scanning electron microscope; JEM-2000FXII transmission electron microscope.

### 2.2 Surface modification of MMT/In composite nano materials and the lubrication system preparation

#### 2.2.1 Nano particle modification

Prepare enough 3 %wt KH550 ethanol solution for the surface modification of nano MMT and In, and then mix a certain amount of nano MMT with above-mentioned KH550 solution, and fully stir it for half an hour at a temperature of about 65 °C, eliminate the solution and make repeated extraction with ethanol, further eliminate the ethanol solution after extraction, dry the solid phase matters in the drying oven, obtaining the nano MMT modified by KH550. Prepare to obtain the nano In modified by KH550 with the same method. Finally, inspect the modification effects of the two with IR.

#### 2.2.2 Preparation of nano MMT/In base oil system

Put KH550 modified nano MMT and In of equal mass respectively into the ethanol solution, forming dispersed systems by stirring and ultrasonic dispersion, and then mix and fully stir the two systems, after filtering and drying, the solid phase and liquid phase are separated, obtaining the blending composite nano MMT/In; prepare to obtain the composite nano MMT/In that isn't modified with the same method.

Add the above prepared two kinds of 1:1 MMT/In composite nano powder into the 150 N base oil by 3 %wt, and fully stir it for 30 minutes, and then disperse it with ultrasonic dispersion instrument for 30 minutes to make the oil sample system for experiment, among which, mark the surface modified nano MMT/In base oil system sample as KMIO, and the unmodified as MIO.

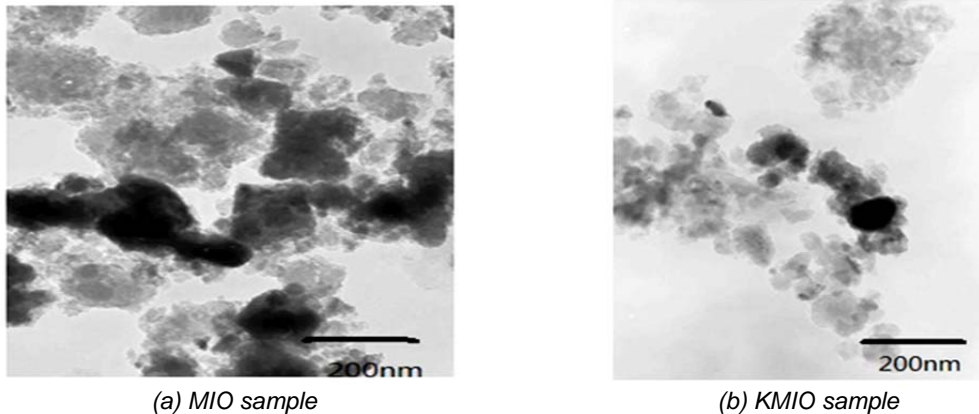

Figure 1: TEM micrographs of MIO and KMIO sample

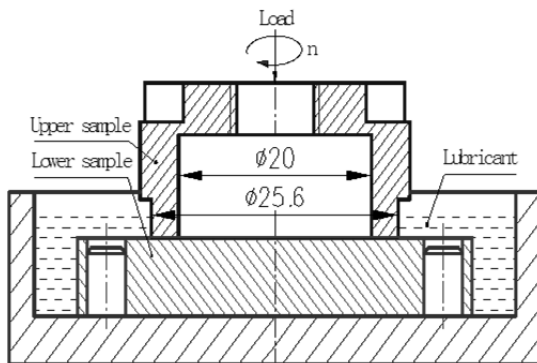

Figure 2: The sketch of friction and wear test

Fig 1(a) is the TEM picture of MIO system, in which the darker color shows the nano In, the lighter color shows the nano MMT, and the particle diameter of agglomeration formed by the two is larger. It is also reflected from the TEM picture in Fig 1(b) that the surface modified nano MMT and nano In almost have no agglomeration phenomenon in the lubrication system, with favorable dispersing performance.

### 2.3 Friction-abrasion test experiment

#### 2.3.1 Friction sample and experimental condition

The friction-wear test is carried out on a MMU-10G friction-wear tester, as shown in Figure 2. The upper sample is a dynamic piece, and the lower sample is a static piece. The upper piece uses the 45<sup>#</sup> steel, and its roughness of the friction surface is Ra 0.8. The bronze mark of the lower sample is ZQSn10-1, and its roughness of the friction surface is Ra 0.8. Test conditions: load 200 N, rotate speed 419 r/min, average oil temperature 50-55 °C, and test time 40 h.

#### 2.3.2 Experiment arrangement and process

Divide the friction sample into two groups, compare their friction-abrasion performance respectively in oil sample BO and KMIO, name the corresponding samples respectively as sample MCB and sample MCMI. Based on the average friction coefficient showed by the MMU-10G model friction-abrasion testing machine in every 10 h, build the friction coefficient-time curve; meanwhile, take down the samples, carry out ultrasonic cleaning successively with petroleum ether and absolute ethyl alcohol, and then weigh them to build up weight loss-time curve. After finishing the friction-abrasion experiment, respectively carry out appearance analysis of the samples with JSM-6490LV SEM, and surface composition analysis with EDX.

## 3. Results and discussion

### 3.1 Test result of the friction coefficient

Figure 3 shows the correlation curve of friction coefficient changes of MCB and MCMI samples with time changes. Within the 40h test time, the average friction coefficient of samples with nanometer MMT/In additive is 0.0350, and the basic oil friction sample is 0.04525, which has reduced by 22.65 %, indicating that the nanometer MMT and In in the lubricating oil can reduce the friction coefficient of the steel-bronze friction pair.

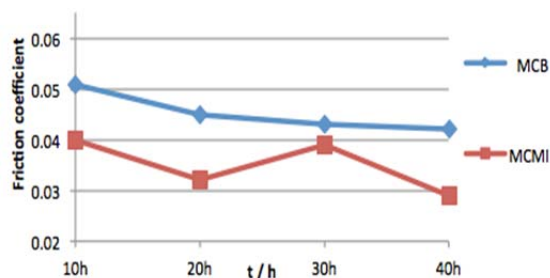

Figure 3: Friction coefficient-time curve

### 3.2 Test result of the wear mass loss

Figure 4 shows the correlation curve of the wear mass loss of MCB and MCMI samples with time. Through 40 h friction and wear, the wear mass loss of MCB sample is 4.2 mg, and that of MCMI sample is 2.2 mg. The abrasion loss has reduced by 47.62 %, indicating the lubrication system of MMT/In composite nano-powder has the abrasive resistance for the steel-bronze friction pair. The changing curve of the wear weight loss of MCB sample increases monotonically. The MCMI sample shows “negative growth” in 10-20 h, and the increase speed of 20-40 h gradually slows down.

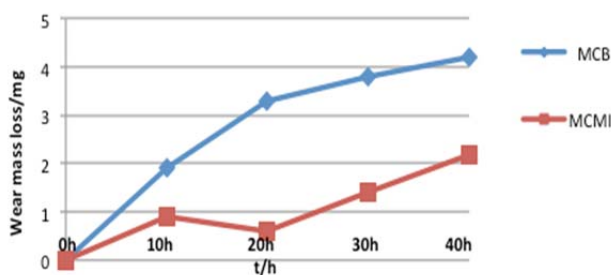

Figure 4: Wear mass loss-time curve

### 3.3 Friction surface analysis

Figure 5 (a) shows the original surface optical photograph of the sample; figure 5 (b) and (c) show the optical photograph of MCB and MCB sample friction look after running for 20 h. The original surface of Figure 5 (a) only has the parallel machining marks; most part of the MCB sample surface shows the metallic copper yellow, indicating there is no substance deposition on the surface in the friction process and the compensation abrasion weight loss is at high level; seen from the surface of the MCMI sample of Figure 7(c), the color of the left area becomes darker with numerous dark substance coverage. The self-repairing membrane is relatively complete and the compensation effect on the abrasion is strengthened.



(a) primary surface of sample



(b) worn surface of MCB sample

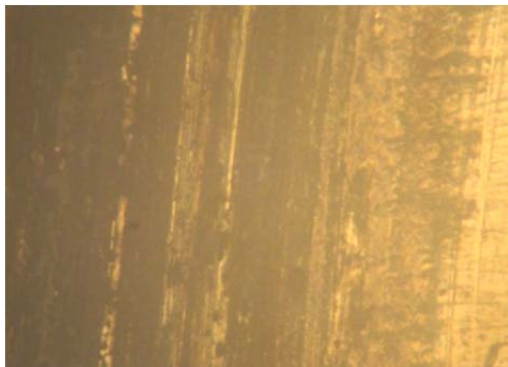

(c) worn surface of MCMI sample

Figure 5: Photos of sample surfaces after 30 h (280 $\times$ )



(a) SEM micrograph of MCB sample worn surface

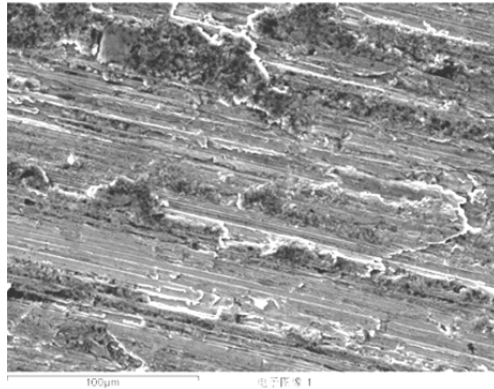

(b) SEM micrograph of MCMI sample worn surface

Figure 6: SEM micrographs of worn surface lubricated with different lubricants after 40 h

Figure 6 (a) and (b) show the superficial look of MCB sample and MCMI sample after friction running for 40 h. The friction scratch of MCB sample is clear and deep with sharp scratch profile. There is no covering on the

surface, and the original processing trace on the surface has almost been grinded. The abrasion is rather serious. As can be seen in the SEM of the MCB sample, thick and large masses of membrane has been covered on the sample surface with bright substance near the membrane mass. The overall coverage region is with large scope, but it does not become the island of repair layer continuously. It is a result of the membrane wear and removal. It also suggests the repair process is with the reverse effect of membrane deposition and abrasion.

### 3.4 EDX analysis of surface components

Figure 7 shows the EDX analysis result of the friction region surface of MCB sample and MCMI sample after 40 h wear and abrasion. Table 1 shows the main element atom fraction table on the friction surface. As can be seen from Figure 7 and Table 1, after 40 h friction, the Al, Mg and In elements have been increased on the friction surface of MCMI sample compared to that of MCB sample, and the In content is especially high, which means the alloy membrane different from the bronze ZQSn10-1 has been formed on the surface of characteristic elements composing MMT and In.

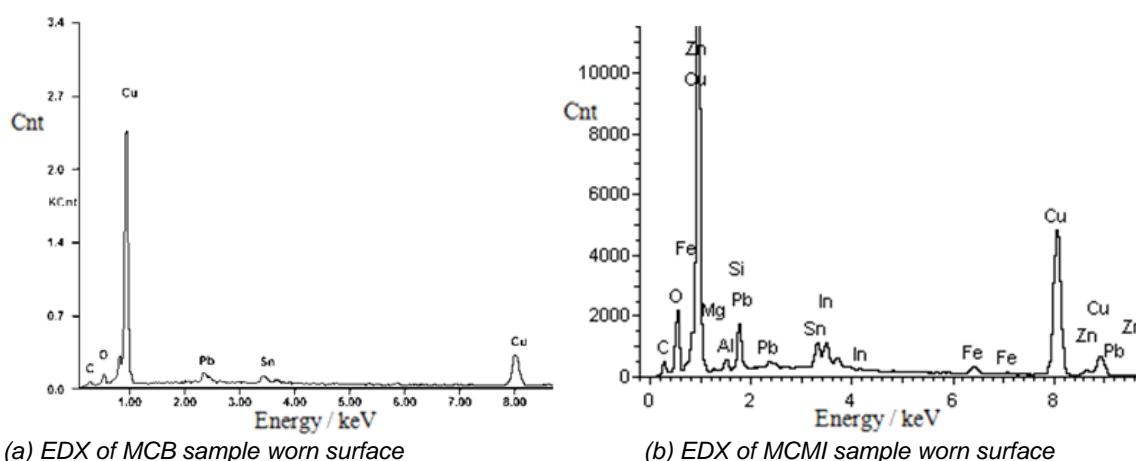

Figure 7: EDX characterizations of sample surfaces after 40 h

Table 1: Elemental atomic percentage of the worn surfaces with different lubricants (%)

Element	Cu	Mg	Al	Fe	In
MCB sample	93.85	0	0	0	0
MCMI sample	86.43	0.35	1.14	0.38	5.49

### 3.5 Mechanism analysis

As can be seen from the above test data and superficial, the repair film composed by In and MMT has been formed on the surface of the bronze. At 20 h, the repair film is the most complete and it is mainly about In, because it is easy for soft metal nanometer In to form the coating membrane on the soft foundation bronze, and the transfer is rather fast along with strong compensation effect. Further, due to the "slight bearing" effect of the MMT particle, the friction coefficient and abrasion are the minimum. When it comes to 30 h, the temperature rises due to the increase of friction. The nanometer MMT spreads and penetrates to the friction surface under certain conditions and forms the alloying layer with In, but the process is rather slow along with weak compensation. The new soft-hard friction pair can be formed by the earlier formed alloying layer and In coating layer, thus forming the plowing effect and making the abrasion and friction coefficient increased. When it reached 40 h, the alloying layer is gradually complete, and the repair effect becomes stable, so the abrasion is not clear compared to the previous stage. The expansion of the alloying layer makes the friction surface more smooth, so the friction coefficient is reduced again.

## 4. Conclusions

- (1) MMT/In composite nano additives have remarkable anti-friction effects on steel-bronze friction pair, during 40 hours of friction process, the average friction coefficient of sample MCMI reduced 22.65 % than that of sample MCB.
- (2) MMT/In composite nano additives have self-repairing capability on 45<sup>#</sup> steel friction pair, the abrasion rate appears negative after 30 hours. During the full 40 hours of friction process, the total abrasion loss of sample MI reduced 63 % than that of sample B.

(3) In the lubrication system with MMT/In composite nano additives, after 40 hours of friction abrasion, by observation with SEM, there are self-repairing films of darker color formed on the surface of steel-bronze friction pair, by inspection with EDX, the surface composition contains the characteristic elements for MMT and In, indicating that there are self-repairing films formed on the surface of the test-piece, greatly improving the anti-friction and abrasion resistant performance of the friction pair, which is the result by joint contribution of nano MMT and nano In.

### Acknowledgements

The Project was supported by the Tribology Science Fund of State Key Laboratory of Tribology (Project No. SKLTKF12A04), the Science and Technology Fund Projects of Guizhou Province (Project No. 20122118 and No. 20112011), the Youth Science Fund Projects of Guizhou University (Project no. 2010053 and No. 2010020), the Introduce Talents Fund Projects of Guizhou University (Project No. 2011013).

### References

- DONG L., CHEN G.X., FANG J.H., 2009, Tribological and Repairing Performances of Mg-Sn Composite Nanoparticles[J]. *Acta Petrolei Sinica(Petroleum Processing Section)*, (25): 67-72. (in Chinese)
- GAO X.L., WU L., LI J., 2010, Study of wear self-repair of steel 100Cr6 rubbed with lubricants modified with Schiff base copper complex [J]. *Journal of Tribology*, 132(3): 034504-1-034504-5.
- GU Z.M., GU C.X., FAN S.Q., 2007, Study on Lubricating Oils Containing Mixtures Additives of Nano-CaCO<sub>3</sub> and Nano-Cu [J]. *Journal of Materials Engineering*, (2): 19-22. (in Chinese)
- KONG X.M., ZHANG S., WEN S.Z., 1997, Experimental Study on the Friction and Wear Characteristics of Steel-copper Pairs [J]. *Lubrication Engineering*, (2): 17-20. (in Chinese)
- LI J., ZHANG S.M., WU Z.S., 2006, Ag Nanoparticles: Preparation in Functional Ionic Liquid and Friction Properties [J]. *Chinese Journal of Inorganic Chemistry*, 22(1): 65-68. (in Chinese)
- QIAO Y.L., 2005, *Lubrication of the Nanoparticles and Self-healing Techniques* [M]. Beijing: National Defence Industry Press, (in Chinese)
- SHAO X., TIAN J., LIU W.M., 2002, Tribological Properties of SiO<sub>2</sub> nanoparticle filled-phthalazine ether sulfone / phthalazine ether ketone (50/50 mol%) copolymer composites [J]. *Journal of Applied Polymer Science*, 85(10): 2136-2144.
- WU X.M., ZHOU Y.K., YANG L., 2012, Tribological Effects of Palygorskite / Copper Nanocomposites as Lubricating Oil Additive on HT200 Tribo-pair [J]. *Journal of Materials Science and Engineering*, (2): 222-226. (in Chinese)
- YANG L., ZHOU Y.K., LI Y., 2012, Investigation on Auto-restoration Performance of Palygorskite / Ag Composite Nanomaterial Additive[J]. *Journal of Materials Engineering*, (3):12-16. (in Chinese)
- ZHANG J.X., LIU K., HU X.G., 2002, Effect of Ultra-Dispersed Diamond Nanoparticles as Additive on the Tribological Properties of 15W/30 Engine Oil [J]. *Tribology*, (1): 44-48. (in Chinese)