

# Study for the Reconfiguration of Cooling Water Networks in Retrofit Scenarios

Jin-Kuk Kim

Department of Chemical Engineering, Hanyang University, 22 Wangsimni-ro, Haengdang-dong, Seongdong-gu, Seoul 133-791, Republic of Korea  
 jinkukkim@hanyang.ac.kr

Conventional cooling water systems are typically based on once-through usage of cooling water for each cooler. Cooling water between coolers can be re-used, which allows reducing overall cooling water flowrate at the increased cooling water return temperature (Kim and Smith, 2001). This reuse concept for cooling water can provide new debottlenecking options by effectively utilizing existing cooling tower. However, care must be taken for the implementation of cooling water reuse in retrofit scenarios, as temperature difference between process streams and reused cooling water is likely to be decreased and hence feasibility of heat transfer for coolers may not be sustained. This study investigates impacts resulted from the reconfiguration of cooling water network when cooling water reuse is introduced for debottlenecking of existing cooling water systems. Conceptual design guidelines are provided to regain driving force of heat transfer for coolers by increasing cooling water flowrate for the cooler. Case study is given to illustrate how cooling water network should be reconfigured for retrofit cases in which overall cooling water flowrate is considerably reduced without compensating performance of coolers.

## 1. Design methodology for cooling water networks

The effective use of cooling water in process industries is important in order to reduce costs related to the provision of cooling water, as well as to contribute sustainable manufacturing through less withdraw of water resources. The use of cooling water is often based on recirculating systems in which water removes heat from process stream, return to the tower and reject its heat to the air within the tower before reusing in the process. Such recycling of cooling water can reduce water consumption considerably, compared to once-through systems, although more careful consideration should be made to deal with problems related to fouling resulted from recycling.

Conventional configuration of cooling water network is based on the parallel use of cooling water between coolers, in which cooling water used in the coolers is all returned to the tower without being reused. There is an economic incentive to reduce overall cooling water flowrate required by reusing cooling water between coolers, if this is allowed. The reuse of cooling water between coolers can be systematically identified by defining a cooling water limiting profile (Kim and Smith, 2001), as illustrated in Figure 1. Feasible design area for cooling operation without violating minimum temperature approach can be determined through defining limiting conditions for cooling water use.

Once limiting Cooling Water Profiles for each cooler is obtained, Cooling Water Composite Curve can be constructed by combining all the heat duty change within the same temperature interval and representing a single line as shown in Figure 2. This composite curve shows overall characteristics of cooling water use for the whole cooling water network, which can be a design basis for reducing cooling water requirement in a holistic manner. This graphical method has been widely used for heat recovery problems to minimize hot and cold utilities required for the process and was extended to other industrial applications, initially design of site utility systems (Klemeš et al., 1997) and later water systems and hydrogen management (Klemeš et al., 2010). A an overview was provided by Klemeš (2012).

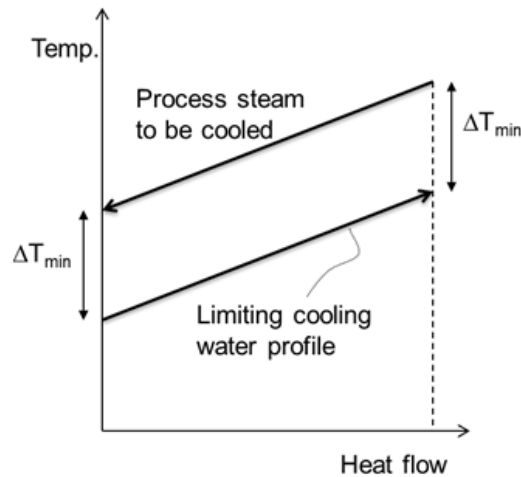

Figure 1: Cooling water limiting condition (after Kim and Smith, 2001)

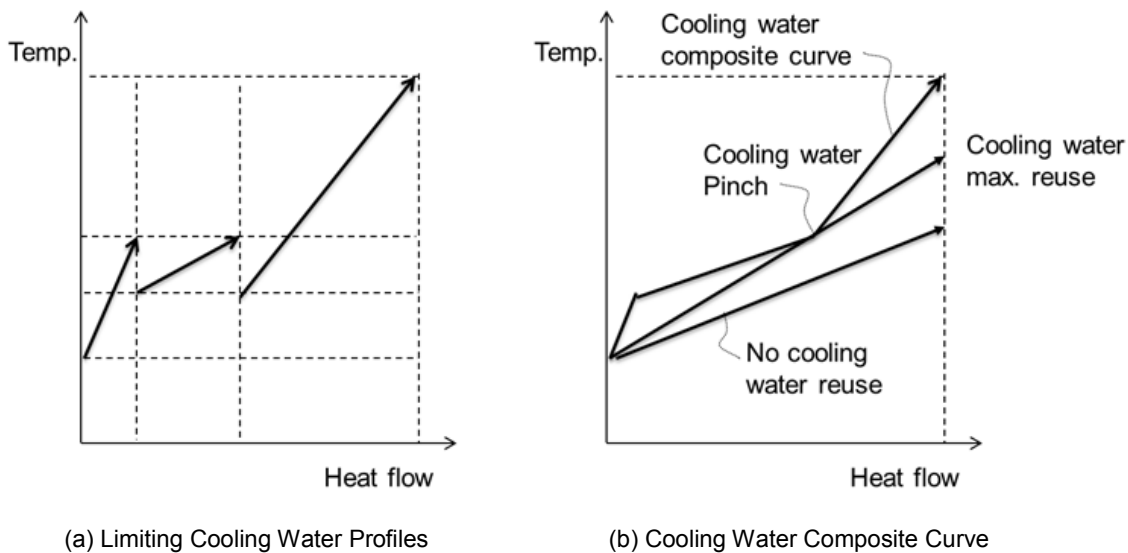

Figure 2: Cooling Water Composite Curve (Kim and Smith, 2001)

The benefits of using cooling water composite curve is to provide conceptual insights for reducing overall cooling water flowrate for the plant as well as to allow systematic investigation of complex design interactions between coolers. Potential for the reuse of cooling water within the network can be identified by drawing a cooling water supply line against the Cooling Water Composite Curve as illustrated in Figure 2(b), in which the slope of the supply line can be varied as long as design feasibility is maintained (i.e. the supply line should be located below or at the Cooling Water Composite Curve.) The Cooling Water Pinch is created when the supply line is touched with the Composite Curve. This Pinch Point represents the minimum driving force available for achieving maximum reuse of cooling water for the network, which allows calculating the minimum cooling water flowrate.

Maximum reuse of cooling water may be chosen as optimal conditions for minimizing cost of cooling water systems. Achieving maximum re-use of cooling water may result in high cooling water return temperature due to reduction of cooling water consumption. However, there may be a material-related limitation for the cooling water return temperature to the tower. Also, significant reduction in overall cooling water flowrate may not be favoured because increasing cooling water reuse for the cooling water networks may increase considerable heat exchanger areas for coolers or power requirements for cooling water pumping (Kim and Smith, 2004). For such cases, cooling water supply lines other than maximum re-use case may be selected for the target cooling water flowrate.

Identifying the most appropriate cooling water flowrate can be sought between two bounds, namely, cooling water supply line with maximum re-use of cooling water which is limited by the Cooling Water Composite Curve, and cooling water supply line without no re-use of cooling water which is based on parallel configuration the coolers. For the case of having no Pinch between the Composite Curve and the supply line, further adjustment for the Composite Curve is needed, with which a Pinch Point is created. The adjustment of Cooling Water Composite Curve is based on shifting concept for limiting Cooling Water Profiles, of which details can be found in the reference (Smith, 2005). Please note that simultaneous consideration between performance of a cooling tower and design of cooling water networks may be needed if variance in cooling water target flowrate and temperature should be considered in evaluating outlet temperature of cooling water regenerated from the tower. This is the retrofit case where operating performance of existing tower should be taken into account in the design of cooling water networks. Water mains method developed by Kuo and Smith (1998) has been adopted for the design of cooling water network as illustrated in Figure 3. Cooling water requirement for each main is first calculated and connectivity information between sources and sinks are obtained through manipulation of mass balances related to limiting cooling water profiles and cooling water to be used or discharged from the main. With cooling water main methods, network configuration of coolers containing reuse of cooling water is identified. As matching between source and sinks of cooling water may have more than one option, final configuration of cooling water networks is often determined at the discretion of designers.

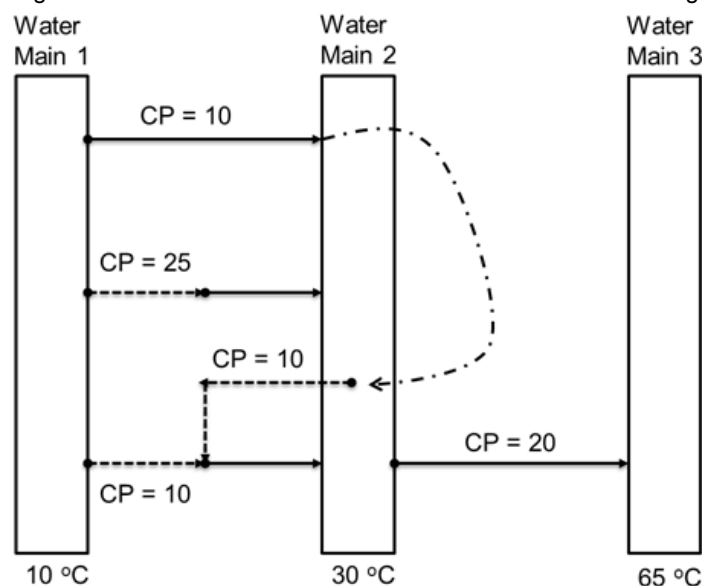

Figure 3: Illustration of cooling water mains method (Smith, 2005)

## 2. Case Study

Case study considered in this work is one of case studies reported in Kemp (2007), in which heat integration for the heat recovery systems of crude oil pre-train was carried out. Figure 4 shows the overall heat exchanger network considered as a case study of cooling water systems in this report. There are five coolers using cooling water within the network, of which data are extracted for the case study, while one cooler using air as a cooling medium is not considered. As no detailed information about cooling water was indicated in the original reference of Kemp (2007), cooling water inlet temperature is assumed to be 18 °C with 10 °C of temperature increase for each cooler. Complete cooling water data is given in Table 1 with 20 °C of  $\Delta T_{min}$ .

Limiting cooling water profile for each cooler is determined with the application of 20 °C for  $\Delta T_{min}$  in the cooler. Also, 50 °C is assumed to be maximum temperature allowed for the cooling water return temperature. 40 °C of inlet cooling water temperature is further assumed when 50 °C is taken due for outlet cooling water temperature due to temperature constraint. Procedure for defining limiting cooling water profiles for Cooler C1 and C3 is illustrated in Figure 5 and resulting limiting conditions are given in Table 2.

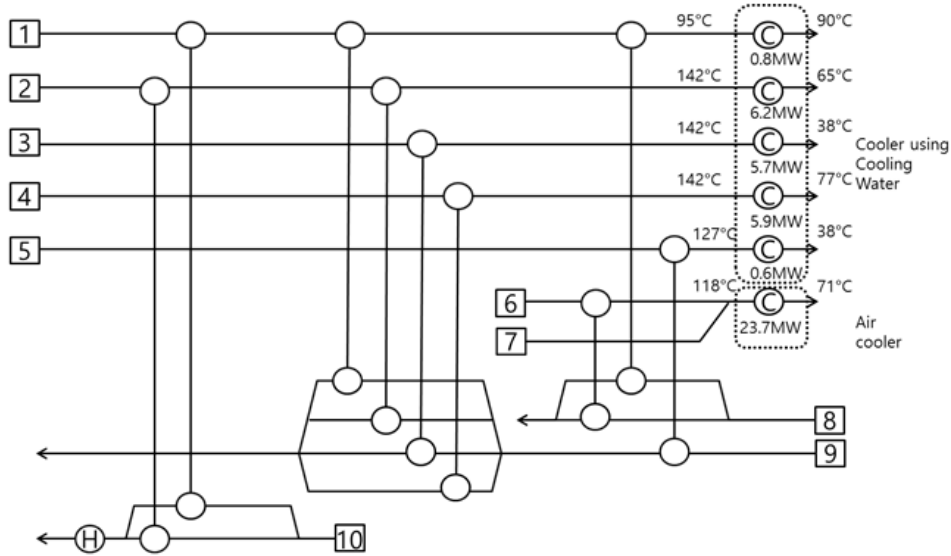

Figure 4: Grid Diagram of Heat Exchanger Network for a case study (Kemp, 2007)

Table 1: Case study – cooling water data

Unit	$T^{CW}_{in}$ [°C]	$T^{CW}_{out}$ [°C]	Q [MW]	CP [kW/°C]
C1	18	28	0.8	80
C2	18	28	6.2	620
C3	18	28	5.7	570
C4	18	28	5.9	590
C5	18	28	0.6	60

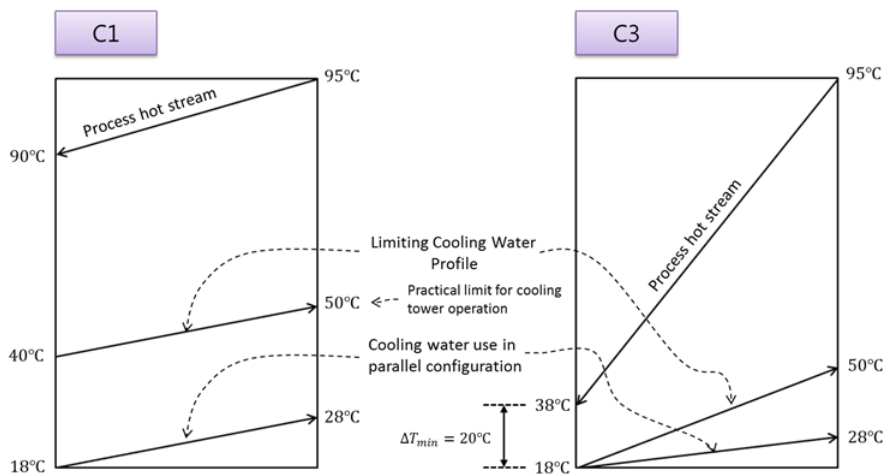
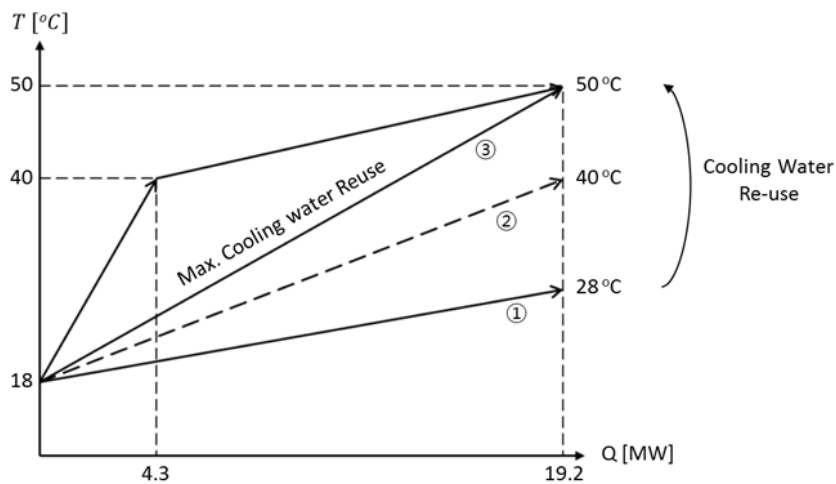

Figure 5: Case study: determination of limiting cooling water conditions

Minimum cooling water flowrate can be obtained by increasing the slope of cooling water supply line shown in Figure 6, in which the supply line without having no cooling water reuse is changed from point ❶ to ❷. About 69 % of cooling water flowrate can be reduced by maximising cooling water reuse. As explained in the previous section, some intermediate cooling water supply line between two bounds, namely, point ❶ and point ❷ in Figure 6, may be taken for economic reason and/or operating limitation. One of target cooling water flowrate with 40 °C as a cooling water return temperature is drawn in Figure 9, which is illustrated in point ❸, with which 55 % of cooling water flowrate is reduced, compared to cooling water required in the parallel configuration.

Table 2: Case study – limiting cooling water data

Unit	$T^{*CW}_{in}$ [°C]	$T^{*CW}_{out}$ [°C]	Q [MW]	CP [kW/°C]
C1	40	50	0.8	80
C2	40	50	6.2	620
C3	18	50	5.7	178.1
C4	40	50	5.9	590
C5	18	50	0.6	18.8



Cases	$CP_{overall}$ [kW/K]	$T^{out}_{overall}$ [°C]
① No Cooling Water re-use	1920 (100%)	28
② Cooling Water re-use	872.7 (45.5%)	40
③ Max. Cooling Water re-use	600.0 (31.3%)	50

Figure 6: Case study: Minimizing cooling water flowrate

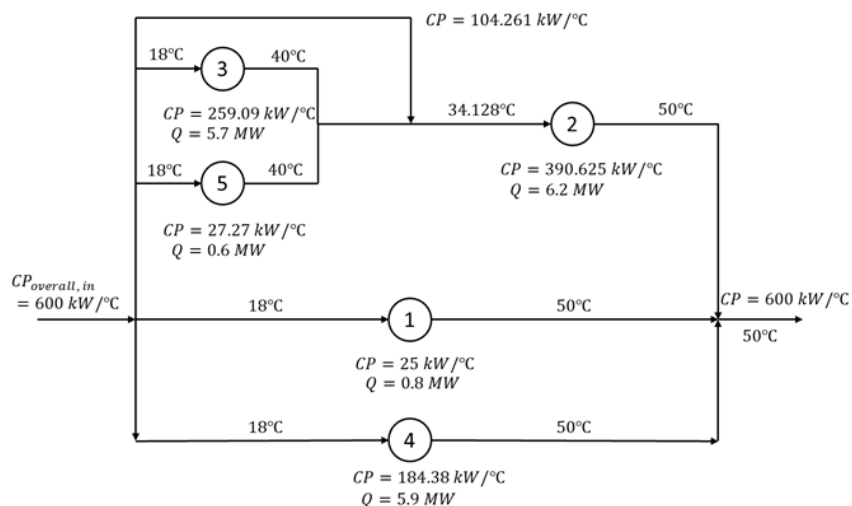

Figure 7: Case study: Cooling water network with maximum re-use

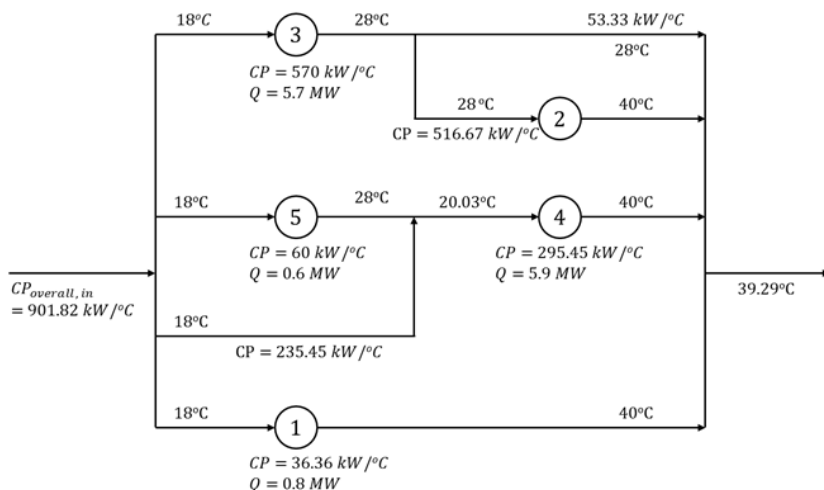

Figure 8: Case study: Cooling water network with about  $40^\circ\text{C}$  of cooling water return temperature

Network configurations for coolers are given in Figures 7 and 8. Figure 7 shows the network with maximum cooling water reuse, while Figure 8 is the simplified configuration evolved from the network with  $40^\circ\text{C}$  as a cooling water return temperature. Simplification in Figure 8 is made by keeping  $28^\circ\text{C}$  for outlet cooling water temperature from the cooler when cooling water is reused.

### 3. Conclusion

The cooling water can be re-used between coolers which can effectively reduce water consumptions in the cooling water systems. However, such design strategy for cooling water re-use leads to reduction in driving force for heat transfer, which may cause infeasible operation in coolers. In this study, we investigate the concept of increasing cooling water flowrate for the coolers to which reused cooling water is fed. A case study has been presented to explain how reduced temperature difference in coolers can be compensated by increasing cooling water flowrate, and to demonstrate the applicability of the proposed design method in practice. As addressed by Sun et al. (2014), consideration of pressure drop is one of important issues in reused cooling water network. However, the current study does not consider the impact of pressure drop and potential limitation associated with pumps, which can be studied further in future. Another area of further investigation can be to incorporate detailed performance of heat exchangers for the coolers, as Pan et al. (2011) combined modelling of heat exchangers with heat recovery networks.

### References

- Kemp I., 2007, Pinch Analysis and Process Integration. 2<sup>nd</sup> ed, Elsevier, Oxford, UK.
- Kim J., Smith R., 2001, Cooling Water System Design, Chem. Eng. Sci., 56, 3641-3658.
- Kim J., Smith R., 2004, Automated Retrofit Design of Cooling-Water Systems, AIChE Journal, 49(7), 1712-1730.
- Klemeš J., Dhole V.R., Raissi K., Perry S.J., Puigjaner L, 1997, Targeting and Design Methodology for Reduction of Fuel, Power and  $\text{CO}_2$  on Total Sites, Applied Thermal Engineering, 17, 993-1003
- Klemeš J., Friedler F., Bulatov I., Varbanov P, .2010, Sustainability in the Process Industry, McGraw-Hill, New York, USA.
- Klemeš, J.J, Industrial Water Recycle/Reuse, 2012, Current Opinion in Chemical Engineering, 1, 238-245
- Kuo W.J., Smith R., 1998, Designing for the Interactions between Water-Use and Effluent Treatment, Trans IChemE, 76, 287-301.
- Pan M, Bulatov I., Smith R., Kim J, 2011, Improving Energy Recovery in Heat Exchanger Network with Intensified Tube-side Heat Transfer, Chem. Eng. Trans., 25, 375-380.
- Smith R, 2005, Chemical Process Design and Integration, Wiley, Chichester, UK.
- Sun J., Feng X., Wang Y. 2014, Optimisation of Cooling-Water Systems Considering Temperature-Rise and Pressure-Drop, Chem. Eng. Trans., 39, 49-54