

Dehydration of Isopropanol by Batch Heteroazeotropic Distillation with Toluene as Entrainer

Bence Nemeth, Laszlo Hegely*, Peter Lang

Budapest University of Technology and Economics, Department of Building Services and Process Engineering, Hungary, H-1111, Budapest, Muegyetem rkp. 3-9.
hegely@mail.bme.hu

The dehydration of isopropanol (B) by batch heteroazeotropic distillation (BHAD) is studied by dynamic simulation. The mixture also contains methyl ethyl ketone (A) and toluene (E) as pollutants. The water (C) content of the feed (ca. 2 mass%) is much lower than that of the B-C azeotrope. B can be obtained as residue by conventional batch distillation (BD) under a very high reflux ratio and considerable loss of B, only. The loss of B can be considerably decreased by BHAD. Toluene, already present in the mixture, can be a suitable entrainer (E), since it forms a ternary heteroazeotrope with isopropanol and water.

Dehydration is feasible by Mode II, Strategy A of BHAD, that is, the two liquid phases of the condensate are separated in a decanter, and the whole amount of E-rich phase is refluxed, while that of E-lean phase is withdrawn as distillate. As the production is very slow because of the high (E-rich/E-lean) phase ratio, several operational strategies are studied in order to make it faster. These include taking a homogeneous fore-cut to remove methyl ethyl ketone, and Strategy B of Mode II, where part of the E-rich phase is also taken as distillate.

1. Introduction

Batch distillation (BD) is frequently applied for the separation of mixtures with varying amount and composition, e.g in the fine chemical, pharmaceutical industry, and in solvent recovery. For the separation of azeotropic mixtures, special distillation methods, such as batch extractive or heteroazeotropic distillation must be applied (Luyben and Chien, 2010). By batch heteroazeotropic distillation (BHAD), an entrainer (E) is added in batch to the binary mixture before the start of the distillation. E forms at least one heteroazeotrope with the original components. The liquid-liquid split (decantation) makes the separation feasible.

BHAD can be performed by two operational modes (Skouras et al, 2005). In Mode I, distillation and decantation are performed sequentially (the whole amount of the E-rich phase is withdrawn with the E-lean one) while in Mode II simultaneously. For Mode II, two strategies are distinguished (Koehler et al., 1995). By Strategy A, the whole amount of the E-rich phase is refluxed, by Strategy B, one part of this phase is also withdrawn (Rodriguez-Donis et al., 2002). Strategy B requires more E, and can be an alternative to Strategy A if the feed already contained E in sufficient amount. By Mode II, the compositions of the reflux and the distillate are different. Therefore, the molar, mass and volumetric reflux ratios (R) are not identical, and R must be defined by giving the dimension of the streams. The reflux ratio of the individual phases, such as that of the E-rich phase for Strategy B, can also be defined. Isopropanol is a common industrial solvent, which forms a minimum boiling azeotrope with water. It can be dehydrated by using batch extractive distillation (BED) using a suitable E, such as dimethyl sulfoxide (Yao et al., 2007). A three-batch process with off-cut and entrainer recycle was optimized by Hegely and Lang (2017). However, dimethyl sulfoxide has a high boiling point (189 °C) that limits its applicability. The use of BHAD was also studied with cyclohexane (e.g. Mussati et al., 2006; Van Baelen et al., 2010). Other possible entrainers were identified by Gmehling and Möllmann (1998) including toluene. In this work, the recovery of B from a four component waste solvent mixture, containing methyl ethyl ketone (A), B, water (C) and toluene (E), is studied. Our goal is to study several operational policies of batch heteroazeotropic distillation with toluene as entrainer, by choosing the values of the operational parameters that enable obtaining high recovery and speed of production. The results are

compared to those of BD. The maximum possible recovery of B is also determined both for BD and BHAD. The calculations are performed by using the dynamic modules of ChemCAD.

2. Phase equilibrium conditions

The components form seven minimal boiling point azeotropes. Table 1 presents the measured and calculated compositions and boiling points of the azeotropes and the boiling points of the pure components. The measured data were taken from Hegely and Lang (2018), where the exact references can be seen. UNIQUAC model was used for describing the vapour-liquid and liquid-liquid equilibria of the mixture. The binary interaction parameters (Hegely and Lang, 2018) were chosen to obtain the best agreement of the measured and calculated data. The calculated composition of the BCE ternary azeotrope is closer to the binodal solubility curve than the measured one. The closer the composition to the equilibrium curve, the lower the amount of aqueous phase is. This means that the production by BHAD with the modelled phase equilibrium conditions is slower than it would be in reality.

Table 1: Measured and calculated (in brackets) VLE and LLE data

Boiling point °C	Components	Composition, mol %			
		A	B	C	E
73.4 (-)	ABC	66.0 (-)	0.9 (-)	33.1 (-)	-
73.5 (72.8)	AC	66.9 (66.4)	-	33.1 (33.6)	-
	Organic phase	65.3 (66.9)	-	34.7 (33.1)	-
T=25 °C	Aqueous phase	7.9 (7.8)	-	92.1 (82.2)	-
76.3 (76.6)	BCE	-	33.6 (36.4)	38.5 (37.7)	28.0 (25.9)
	Organic phase	-	34.3 (38.2)	18.8 (27.8)	47.0 (34.0)
T=25 °C	Aqueous phase	-	12.2 (13.2)	87.5 (85.7)	0.3 (1.1)
77.7 (77.6)	AB	61.6 (68.8)	38.4 (31.2)	-	-
79.9 (79.6)	A	1	-	-	-
80.4 (80.0)	BC	-	68.3 (67.6)	31.7 (32.4)	-
81.3 (81.3)	BE	-	83.8 (81.3)	-	16.2 (18.7)
82.5 (82.3)	B	-	1	-	-
85.0 (84.8)	CE	-	-	56.4 (56.4)	43.6 (43.6)
	Organic phase	-	-	0.28 (1.3)	99.72 (98.7)
T=25 °C	Aqueous phase	-	-	99.99 (99.87)	0.01 (0.13)
100.0 (100.0)	C	-	-	1	-
110.8 (110.6)	E	-	-	-	1

3. Sequence of the cuts for maximal separation

The composition of the feed, mol%: A: 1.61, B: 89.30, C: 7.08, E: 2.01. The sequence, amount of the cuts and recovery of B (η_B) obtained at maximal separation (very high N and R) were determined for batch conventional (BD) and heteroazeotropic distillation (BHAD, Mode II, Strategy A) using the algorithm of Hegely and Lang (2011). In Table 2, the amounts of the cuts are presented for 117.33 kmol feed and for different amounts of E added. The calculations were performed using the measured azeotropic data.

Table 2. Results of the product sequence calculations with the addition of E.

	BD					BHAD					
	E added, kmol	0	0.14	0.64	1.64	2.64	0	0.14	0.64	1.64	2.64
Cuts, ABC	2.86	2.86	2.86	2.86	2.86	ABC	2.86	2.86	2.86	2.86	2.86
kmol BCE	8.46	8.97	10.76	14.34	17.93	BCE E-lean phase	8.75	8.75	8.75	8.75	8.75
BC	12.93	12.32	10.15	5.79	1.44	BE	13.75	14.58	17.52	23.40	29.28
B	93.08	93.32	94.21	95.98	97.75	B	91.97	91.28	88.84	83.96	79.08
η_B , %	88.8	89.1	89.9	91.6	93.3		87.8	87.1	84.8	80.1	75.5

The first cut is the ABC ternary azeotrope, whose amount is constant. By BD, E is then removed with the BCE azeotrope, whose amount is proportional to that of the E added. C is removed with the BC binary azeotrope,

finally B is obtained in the still. The amount of BC decreases with that of the E added, and if enough E is present, the third cut changes to BE. η_B increases with the amount of E, because the loss of B is lower if C is removed with the BCE azeotrope. By BHAD, the second cut is the E-lean phase of the BCE azeotrope. As the whole amount of C is removed with it, its amount does not depend on that of E. The addition of E increases the amount of the BE cut, and thus reduces η_B . Even without the addition of E, η_B is higher for BD. As it will be shown later, this is not the case under real conditions. It is likely that for every N and R value, there exists a critical R and N value, below which the application of BHAD give a higher recovery.

4. Operational policies

Several operational policies were investigated: conventional BD, for BHAD Mode II Strategy A and a new, combined strategy (Strategy A+B). The purity requirements for the product:

1. The water content ($x_{W,C}$) in the still is lower than 0.2 vol. % (0.83 mol %)
2. The IPA content ($x_{W,B}$) in the still is higher than 99.77 mol %.

The conventional BD has the following steps:

0. Warming up of the charge and heating up of the column under total reflux ($R=\infty$). This step is finished 60 minutes later, after the vapour reached the top of the column.
1. Taking of fore-cut under finite reflux ratio ($R_1<\infty$) until both purity criteria are reached.

The BHAD (Strategy A) has the following steps:

0. Addition of E (optional), warming up of the charge and heating up of the column under $R=\infty$. As the feed originally contains E, the additional amount of E is an optimisation variable. The end of this step is when the two liquid phases appear in the decanter (its hold-up is neglected) or the two liquid phases reach their specified levels (its hold-up is taken into consideration).
1. Withdrawal (decantation) of the E-lean (aqueous) phase until the aqueous phase disappears or the first purity criterion is reached (in case of larger amount of additional E).
2. Removal of the remaining A, C (if the first purity criterion in Step 1 is not reached) and E by BD to fulfil the second purity criterion. In this step, the optimisation variable is the reflux ratio (R_2).

By Strategy B, one part of the E-rich phase is also withdrawn, but with this phase more B and E are lost (see the composition of the organic phase of the BCE azeotrope). By Strategy A the flow rate of the E-lean phase strongly diminishes at the end of Step 1 resulting in very high R in the column (which is increasing while the flow rate of the E-lean phase is decreasing) and in very slow distillate withdrawal.

Therefore, we suggest combining these strategies by dividing Step 1 into two parts: in Step 1b, Strategy B is applied. The criterion for finishing Step 1a and the ratio of the E-rich phase withdrawn (with reflux ratio R_E) are new optimization variables. Step 1a is finished when $x_{W,C}$ reaches a prescribed value (Cr). The reflux ratio in Step 2 equals to that of the E-rich phase in Step 1b ($R_2=R_E$). The application of Strategy B also promotes the removal of the E excess.

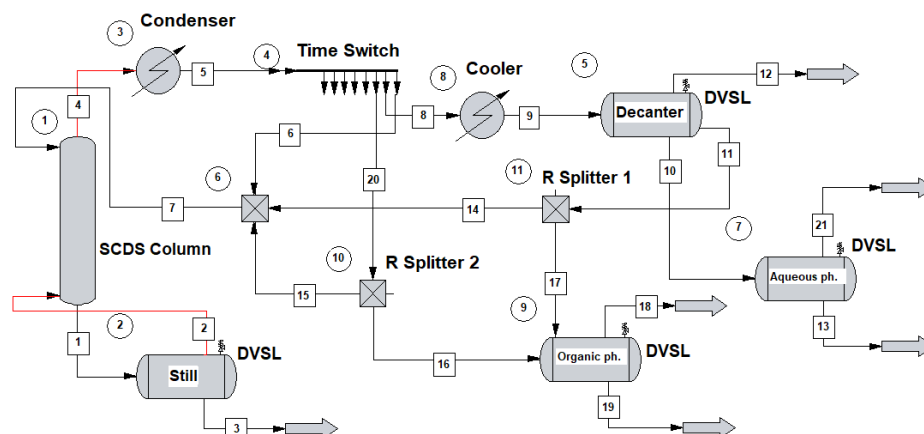

Figure 1: CHEMCAD flowsheet (BHAD).

5. Simulation results

The CHEMCAD professional flowsheet simulator was used for modelling the dehydration of IPA. Figure 1 shows the flowsheet of BHAD that can be used both for Strategy A and the combined strategy depending on whether Stream 11 is split in R Splitter 1.

The decanter was modelled with a Flash module, when its hold-up was neglected. By Strategy A, the condensate goes to Stream 8 after Step 0 and a heat exchanger cools it to 25 °C. The total amount of the organic phase is refluxed, so R Splitter 1 is not operating in this case. In Step 2, R_2 is adjusted in R Splitter 2. In the case of Strategy A+B, the condensate also goes to Stream 8 after Step 0, then in Step 1a, the total amount of organic phase is refluxed (R Splitter 1 is not operating). In Step 1b, R_E is adjusted in R Splitter 1. In Step 2, the condensate goes to Stream 20 and the reflux ratio ($R_2=R_E$) is adjusted in R Splitter 2.

Input data for the dynamic simulation: the column was modelled with 10 theoretical plates (excluding the condenser and reboiler), the hold-up of the condenser was 25 dm³, that of the column 4 dm³/stage, heat duty of the reboiler: 750 MJ/h. The volume of the charge was 8.5 m³ (without the E added). The decanter was modelled both without and with hold-up. In the latter case the dimensions of the decanter (d=0.5 m, h=1 m) were calculated to obtain at least 5 min residence time. The decanter is operated at 25 °C.

5.1 BD

The influence of R_1 on the B recovery (η_B) and speed of production (specific product flowrate, SPF: the ratio of the amount of product B and the duration of the process) was studied (Table 3). As the heat duty is constant, at the maximal SPF, the specific energy consumption is minimal. At $R_1=13.3$, SPF is maximal, but η_B is the lowest. $R_1=19$ is a trade-off between the specific flow rate and B recovery. The higher R_1 , the higher η_B can be reached, but the SPF is significantly decreasing.

Table 3: The influence of R_1 on the B recovery and SPF (BD).

R_1	Process duration, h	SPF, kmol/h	η_B , %
13.3	34.4	2.12	69.57
15.7	36.6	2.09	72.88
19.0	39.6	2.01	76.12
24.0	44.5	1.87	79.21
32.3	51.3	1.67	81.96

5.2 Strategy A

The influence of the amount of E (U_{ch}^E) and R_2 on the B recovery and SPF was studied. In Table 4, the numbers in brackets give the additional amounts of E (ΔU_{ch}^E). The SPF has a maximum at $U_{ch}^E=3$ kmol. The more E is added to the pot charge, the more E-lean phase can be withdrawn. Hence the C content can be decreased significantly, but more E remains in the still, which must be also withdrawn in Step 2. These two factors have opposite impacts on the process duration, which therefore has a minimum as a function of U_{ch}^E . The increase of U_{ch}^E leads to a decrease in η_B , because the removal of additional amount of E causes B loss.

The effect of R_2 is investigated further at $\Delta U_{ch}^E=0.64$ kmol (Figure 2). At $R_2=15.7$, SPF has a maximum, but the recovery is relatively low. However, at $R_2=24$ both SPF and recovery are quite high.

Table 4: The influence of amount of E on the B recovery and SPF (Strategy A, $R_2=19$).

U_{ch}^E , kmol	Process duration, h	SPF, kmol/h	η_B , %
2.36 (0)	60.7	1.38	80.17
2.5 (0.14)	59.5	1.40	79.63
3 (0.64)	57.9	1.42	78.32
4 (1.64)	62.2	1.25	74.34
5 (2.64)	66.8	1.12	71.13

5.3 Combined strategy (Strategy A+B)

The influence of the following parameters were studied: ΔU_{ch}^E , Cr, R_E . Though SPF is maximal at $\Delta U_{ch}^E=0.14$ kmol (Table 5), but it is only slightly lower without E addition, which means simpler operation, besides η_B is maximal here, as it decreases with increasing ΔU_{ch}^E . The process duration has a minimum as a function of ΔU_{ch}^E , and it is shorter than that of Strategy A at each value of ΔU_{ch}^E . However, η_B of the combined strategy is slightly higher at every value, and as a result, the SPF is also higher than that of Strategy A. The relative difference of the durations is greater, thus the maximum of SPF is at a lower ΔU_{ch}^E value for the combined strategy. The influence of Cr is further investigated at $\Delta U_{ch}^E=0$ kmol (Table 5). At Cr=1 vol% η_B has a maximum and SPF hardly increases on the further increase of Cr. At higher Cr, less E-lean phase is withdrawn in Step

1, so the C-content of the still cannot be decreased significantly, therefore more C must be removed in Steps 1b and 2, which means higher B-loss and a decrease in η_B . When Cr is lower than 1 vol%, the duration of Step 1b is shorter, than at higher Cr values, which means that less E-rich phase is removed. Consequently, more E remains in the still, so more distillate must be withdrawn in Step 2, which means higher B-loss.

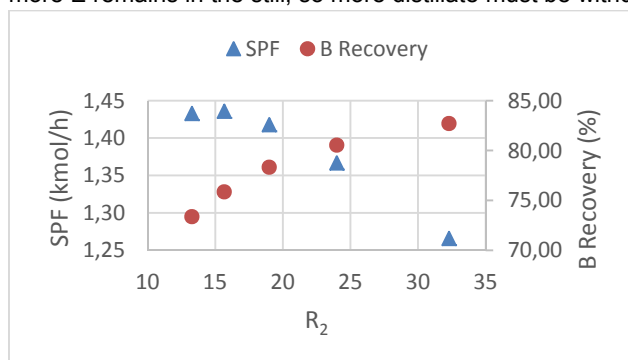

Figure 2: The influence of R_2 on the B recovery and SPF (Strategy A, $\Delta U_{ch}^E = 0.64$ kmol).

Table 5: The influence of the amount of E ($Cr=0.5$ vol%) and that of Cr ($\Delta U_{ch}^E=0$) (Strategy A+B, $R_E=19$).

ΔU_{ch}^E , kmol	Process duration, h	SPF, kmol/h	η_B , %	Cr, vol%	Process duration, h	SPF, kmol/h	η_B , %
0.00	55.0	1.53	80.53	0.4	61.0	1.37	80.08
0.14	54.2	1.54	79.93	0.6	51.1	1.66	80.75
0.64	53.9	1.53	78.72	0.8	46.3	1.83	81.08
1.64	56.4	1.40	75.29	0.9	44.8	1.90	81.26
2.64	60.9	1.24	71.85	1.0	43.7	1.95	81.38
				1.1	42.9	1.98	81.15
				1.2	42.4	2.00	80.94

The influence of R_E is further investigated at $Cr=1$ vol% (Table 6). On the increase of R_E the duration of the process and the recovery increase. SPF is maximal at $R_E=15.7$, but here the recovery is low. At $R_E=24$ SPF is high enough and the recovery is much higher.

Table 6: The influence of R_E (Strategy A+B, $\Delta U_{ch}^E=0$, $Cr=1$ vol%)

R_E	Process duration, h	SPF, kmol/h	η_B , %
13.3	40.6	1.94	75.14
15.7	41.9	1.96	78.22
19.0	43.7	1.95	81.38
24.0	46.3	1.91	84.18
32.3	50.4	1.81	87.17

5.4 Comparison of the different operational policies

The most important results of the different operational policies are summarized in Table 7. The results show good agreement when the decanter was modelled with and without hold-up. SPF was the highest with conventional batch distillation when the decanter hold-up was neglected, otherwise it was the second best. It was also the fastest process. With the parameter values chosen, only the combined strategy of BHAD gave better η_B (by 7 % in absolute values) than the conventional BD, which can be performed in a simpler way. The B production rate of the combined strategy is slightly slower than that of BD. By BD, higher η_B can be reached only at the cost of considerably lower SPF and this recovery is not as high as which can be achieved by the combined strategy. By this strategy, both the specific product flow rate and the recovery were considerably higher than by Strategy A. For the combined strategy, at certain combinations of values of ΔU_{ch}^E , Cr, R_E , both η_B and SPF can be higher than for BD for the same SPF or η_B values, respectively.

In both BHAD operational policies an additional BD step (Strategy A: Step 2, Strategy A+B: Step 1b) was required. In these steps, the main pollutant was E, however with the combined strategy the A-content was also high in the distillate. Therefore, we investigated another policy, in which A was withdrawn first by a BD step, then the combined strategy was applied. When additional E is not required for the separation, the same results were obtained as with the combined strategy. However, when the E concentration is low in the charge

(addition of E required) slightly higher B recovery could be achieved by this policy (withdrawal of A before E addition) than by the combined strategy, but the process duration was much longer, so the SPF significantly decreased. By the results of product sequence calculations for cyclohexane as E, higher η_B can be reached, but introducing a new component into the plant can cause difficulties and production technology becomes more complicated.

Table 7: Comparison of the different operational policies.

Method	ΔU_{ch}^E , kmol	Reflux ratio	Cr, vol%	Duration, h	SPF, kmol/h	η_B , %
BD	-	$R_1=19.0$	-	39.6	2.01	76.12
Strategy A	0.64	$R_2=15.7$	-	55.4	1.44	75.86
Strategy A*				59.4	1.31	74.41
Strategy A+B				46.3	1.91	84.18
Strategy A+B*	0.00	$R_E=24.0$	1.0	42.1	2.07	83.06

*Decanter hold-up simulated

6. Conclusions

Three different operational policies were investigated for the dehydration of a mixture of methyl ethyl ketone(A), isopropanol(B), water(C) and toluene(E) by dynamic simulation with the CHEMCAD professional flow-sheet simulator. These policies were the conventional batch (BD) and heteroazeotropic distillation (BHAD) Strategy A and a new, combined strategy: Strategy A+B. The goal was to obtain high purity isopropanol (99.77 mol%) in the still, which can be achieved by all of these policies. The influence of the amount of entrainer in the charge, the reflux ratios, concentration of water in the still at the end of Step 1a in the combined strategy on the specific production flowrate (SPF) and the recovery was determined.

The best results were obtained by the combined strategy considering the B recovery (η_B): 7 mol % higher η_B than by BD, while the production rate was almost the same (2.01 and 2.07 kmol/h). The purity criterion could be reached by BHAD Strategy A as well, but SPF was considerably lower (1.31 kmol/h) than by BD, because of the slow production (the amount of the E-lean phase withdrawn was decreasing fast). By optimizing Strategy A+B, even higher SPF values might be obtained.

Acknowledgments

This work was financially supported by the Hungarian Scientific Research Fund (OTKA, project No.: K-120083). The publication of the work reported herein has been supported by ETDB at BME.

References

- Gmehling J., Möllmann C., 1998, Synthesis of Distillation Processes Using Thermodynamic Models and the Dortmund Data Bank, Industrial & Engineering Chemistry Research, 37, 3112-3123.
- Hegely L., Lang P., 2011, A New Algorithm for the Determination of Product Sequences in Azeotropic Batch Distillation, Industrial & Engineering Chemistry Research, 50 (22), 12757-12766.
- Hegely L., Lang P., 2018, Influence of Entrainer Recycle for Batch Heteroazeotropic Distillation, Submitted to Frontiers of Chemical Science and Engineering
- Hegely L., Lang P., 2017, Optimisation of Batch Extractive Distillation Process with Entrainer Recycle, Computer Aided Chemical Engineering, 40, 2101-2106.
- Koehler J., Haverkamp H., Schadler N., 1995, Discontinuous Rectification of Azeotropic Mixtures with Use of Auxiliary Substance, Chemie Ingenieur Technik, 67, 967-971 (in German).
- Luyben W.L., Chien I.L., 2010, Design and Control of Distillation Systems for Separating Azeotropes, John Wiley & Sons, Inc., Hoboken, New Jersey, USA, 421-422.
- Mussati M.C., Aguirre P.A., Espinosa J., Iribarren O.A., 2006, Optimal Design of Azeotropic Batch Distillation, AIChE Journal, 52(3), 968-985.
- Rodriguez-Donis I., Gerbaud V., Joulia X., 2002, Feasibility of heterogeneous batch distillation processes, AIChE Journal, 48, 1168-1178.
- Skouras S., Kiva V., Skogestad S., 2005, Feasible separations and entrainer selection rules for heteroazeotropic batch distillation, Chemical Engineering Science, 60, 2895-2909.
- Van Baelen G., Vreysen S., Gerbaud V., Rodriguez-Donis I., Geens J., Janssens B., 2010, Isopropyl alcohol recovery by heteroazeotropic batch distillation. EMChE 2010, Mechelen, Belgium, 979-986.
- Yao J.Y., Lin S.Y., Chien I.L., 2007, Operation and control of batch extractive distillation for the separation of mixtures with minimum-boiling azeotrope, J. Chin. Inst. Chem. Eng., 38, 371-383.