

Elementa

Intersections between Philosophy, Epistemology and Empirical Perspectives

1
(2021)
1-2

Pierpaolo Limone
Editorial 7

FIRST SECTION

Slavoj Žižek
The Vagaries of the Superego 13

Ricardo Espinoza Lolas
Nature and Pandemic 33

Paolo Ponzio
Mask and Otherness between Recognition and Concealment:
Notes on the Self and the You 47

Daniela Savino
“Liquid” Identity and Otherness in the Phenomenon
of Religious Alienation: The Loss of Critical Thinking
and the “Barter” of the Self in the System of Communion 61

Francesca R. Recchia Luciani
The Sexistential Vulnerability of Bodies in Contact
in the Philosophy of Jean-Luc Nancy 85

SECOND SECTION

<i>Martina Rossi</i> Universal Design for Learning and Inclusive Teaching: Future Perspectives	103
<i>Marco Ceccarelli</i> A Historical Account on Italian Mechanism Models	115
<i>Giusi Antonia Toto - Alessia Scarinci</i> Cyberfeminism: A Relationship between Cyberspace, Technology, and the Internet	135
<i>Luigi Traetta - Federica Doronzo</i> Super-Ego after Freud: A Lesson not to Be Forgotten	153
<i>Federica Doronzo - Gianvito Calabrese</i> Functioning of Declarative Memory: Intersection between Neuropsychology and Mathematics	163
<i>Giuliana Nardacchione - Guendalina Peconio</i> Peer Tutoring and Scaffolding Principle for Inclusive Teaching	181

Functioning of Declarative Memory: Intersection between Neuropsychology and Mathematics¹

Federica Doronzo¹ - Gianvito Calabrese²

¹ Learning Science hub, Università degli Studi di Foggia (Italy)

² Yield Engineer on Semiconductor

DOI: <https://dx.doi.org/10.7358/elem-2021-0102-doca>

federica.doronzo@unifg.it
g.calabrese.296@gmail.com

ABSTRACT

The understanding of memory has been a constant challenge for scientific research for centuries. The mnemonic processes, which determine the identity of the human being, have been investigated through multiple points of view, such as the psychological, neurophysiological and physical ones. The result is complex and multifaceted visions that should be integrated to provide a unitary and complete interpretation. A survey of the most recent scientific literature is carried out on the functioning of declarative memory, to analyse the relationship between real information coming from the outside world, the encoded event and the recovered memory. The aim of the essay is to investigate the neural correlates, which regulate the cognitive system in question, through a dual neuropsychological-mathematical interpretation. Neuropsychology sheds light on the anatomical, physiological and psychic mechanisms of memory while Mathematics associates the corresponding mathematical configurations to neural networks. The reunification process between the two disciplines is achieved through neuromorphic computational simulation that emulates mind uploading. The assembly of artificial neurons has the potential to clarify in detail the memory processes, the functioning of neural correlates and to carry out the mapping of the biological brain. We hope that the results obtained will provide new knowledge on mnemonic mechanisms to contribute to the evolution of disciplines such as General Psychology, Forensic Neuroscience, Cognitive Rehabilitation and Awake Surgery.

¹ For the purposes of academic recognition, contributions are attributed as follows: introduction and paragraph 1 to Federica Doronzo; paragraph 2 to Gianvito Calabrese; and the conclusion is the result of a shared work.

Keywords: declarative memory; mathematical configurations; neuromorphic computation; neuropsychology.

INTRODUCTION

Memory is the cognitive domain that mediates a series of processes to acquire and store information over time, the aim is to guide behavior and plan future actions for survival. This function is fundamental for the human being as long-lasting memories form the basis of identity that is a self/hetero perception of oneself and of the relationship between the self and the world. In particular, declarative memory is involved in the integration of individual experiences with the socio-cultural knowledge of the world.

The four fundamental processes of memory are: coding, consolidation, storage and retrieval. Coding is the processing of information (sensory analysis and attribution of meaning), the consolidation allows the generation of a representation, the storage consists in the recording of data in the storage-memory and the recovery phase is the recall mechanism of the memory. Recently Dudai (2012) confirmed the existence of another process, such as reconsolidation which is an extension of the phenomenon of memory consolidation. When a memory is recovered or reactivated it must be consolidated again, increasing the possibility that the reconsolidated memory may include new information not present in the original version of the event.

The multi-warehouse model, which evolved from James' first theorization in 1890, is the most accredited paradigm in the literature and provides for the subdivision of memory into hierarchically organized modules. A fundamental distinction concerns the component of temporal retention which determines the following subdivision: working memory, sensory memory and long-term memory. The latter can be classified into declarative (explicit), that is, conscious memory of events and facts, and non-declarative (implicit) which consists of memories expressed through the execution of actions regardless of awareness.

The most recent model is the MNESIS model, i.e. *Memory Neo-Structural Inter-Systemic*, in which the memory consists of interconnected sub-systems (Eustache, Viard, & Desgranges, 2016). The three modules of long-term representation (perceptual memory, semantic memory, episodic memory) interact with each other through the processes of consolidation²

² Phenomenon of reliving experiences: a still faint trace is converted into a permanent or enhanced form.

and semantization³; the episodic buffer⁴ acts as an intermediary between working memory, procedural memory and long-term memory, and the latter two systems in turn have direct links. The structure demonstrates that memories have a dynamic and reconstructive nature and memory operates through a distributed set of brain areas that are, interconnected neural networks (Fig. 1).

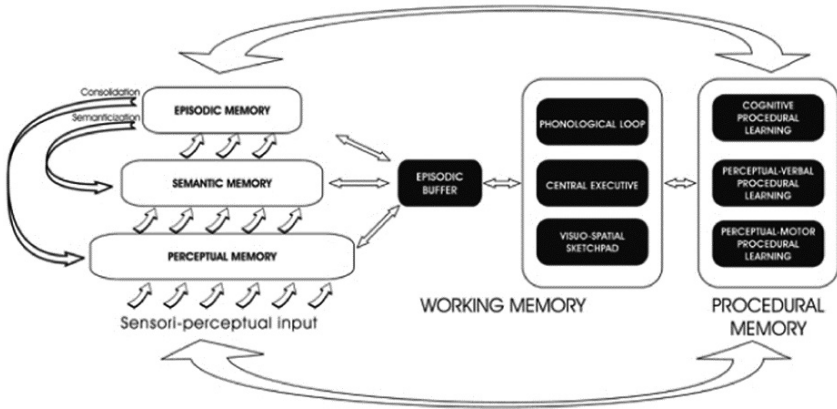

Figure 1. – MNEISIS. Fonte: Eustache, Viard, & Desgranges, 2016, p. 100.

Computational Science is contributing to the understanding of brain functioning by designing artificial brain networks. The modeling of the biological brain has the potential to photograph and reproduce the neural configurations during the different memory processes, distinguishing brain activity for coding, consolidation and information retrieval.

The key issues of the reflection in question are:

- Are past events faithfully reproduced or does the memory function induce constructive activities by distorting the original information?
- Is neuromorphic computing⁵ a feasible project? What repercussions would it have with respect to the understanding of the Central Nervous System?

³ Passage from episodic memory to semantic memory due to the passage of time which induces the loss of episodic details of memories.

⁴ In 2000, Baddeley added episodic buffer to his short-term memory model. This third sub-component acts as an intermediary between systems having different codes, and combines them into unitary, meaningful and coherent representations.

⁵ New paradigm that essentially consists in assembling artificial neurons so that they function according to the principles of the human brain.

The above themes are investigated with a dual point of view, neuropsychological and mathematical, in order to integrate the results and increase knowledge with respect to the cognitive domain of memory. Understanding the psycho-physiological mechanisms associated with memory processes, mapping the human brain and mathematically representing neural configurations, would allow us to answer the aforementioned questions.

These goals would generate innumerable implications: Forensic Neuroscience and Cognitive Rehabilitation would implement assessments and interventions calibrated on the specific functioning of the memory process and brain activity. Furthermore, a transdisciplinary understanding of the construct would enrich the theories and open questions of General Psychology (such as reconstruction and alteration of memories) and would help to ensure greater safety of Awake Surgery: the facilitation of intraoperative mapping would precisely determine the dedicated areas of the brain to fundamental neurological activities and their functioning.

1. NEUROPSYCHOLOGICAL PERSPECTIVE

Neuropsychology has provided a significant contribution to the knowledge on the functioning of declarative memory through the study of both the healthy subject and that affected by diseases of the Central Nervous System. The transdisciplinary nature provides it with an added value, this paragraph investigates the studies and empirical evidences that clarify the declarative mnemonic mechanisms from a psychic and physiological point of view.

1.1. *Construction and reconstruction of declarative memories*

To understand how memory works, it starts by examining its characterizing process: learning. This process, which mediates the consolidation of the traces, is determined by changes involving the synapses for both short-term memory (greater neurotransmitter release) and long-term memory (formation of new synapses). Any experience that results in remembering produces physical changes in the Central Nervous System (CNS). The brain circuits that support the formation, storage and retrieval of declarative memory converge in a hippocampus-dependent system⁶. In 1937

⁶Eichenbaum (2000) demonstrated that rats with hippocampal and parahippocampal lesions lose the ability to retrieve previously acquired memories (specifically spatial ones).

Papez was among the first to identify the circuit involved in the formation of long-term memories, known as the Papez circuit, consisting of the projections from the hippocampal formation to the mammillary bodies and from the mammillary bodies to the anterior thalamus. Squire (2015) most recently identified the main areas of the circuit: medial temporal lobe, hippocampus and primary, secondary and associative cortex. The hippocampus and the diencephalic structures are of crucial importance for the formation and consolidation of memories which are subsequently stored throughout the brain.

Here are four theories that differently describe how episodic memory works.

Squire, in 2004, developed the *Standard consolidation theory* according to which the hippocampus acts as an “index” of access to recent memories for their spatial localization, for example visual elements are stored in the visual cortices, the sounds of words in language areas, etc. Subsequently, the consolidation period allows direct connection to the cortical traces of memories, and the hippocampus is no longer essential for the retrieval of information.

Nadel and Moscovitch (1997) with the *Multiple trace theory* argue that episodic memories, more or less consolidated, are always dependent on the hippocampus. The temporal gradient is not associated with the transfer to the cortex but with the number of traces stored in the hippocampus: every time a memory is reactivated, a new memory trace is stored in the hippocampus. As a result, remote memories are encoded by multiple tracks and become more resistant to hippocampal damage. The recall can therefore alter the memory as a photograph of what really happened is not constructed, but rather a reconstruction of what is remembered the last time one thought about the memory takes place. In 2013 Maguire and Mullally advanced the *Scene construction theory*, according to which the hippocampus is able to reconstruct the past experience in the absence of the original trace. During the re-enactment of a recent event, the hippocampus constructs a series of coherent scenes with event through neocortical-hippocampal interactions. These scenes quickly fade from the hippocampus as the representations consolidate into adjacent cortical areas.

Schacter and Addis (2007), with the *Episodic simulation of future events*, argue that the memory of the past and the imagination of the future draw on similar information stored in episodic memory, which therefore also supports the construction of future events by extracting and recombining the information stored in a simulation of a new event.

Bartlett provides another element in support of the distorted nature of memory by proposing a constructive vision of memory as early as the

first half of the 1900s. Cognition would not allow a duplicative process of reality as it is impossible to separate memory from other higher functions such as thought and imagination. Memory therefore plays a role of active transformation of memories by integrating perception and subjective experience. This phenomenon is due to the presence of patterns, e.g. knowledge that everyone has about objects or events, which guide the memory processes.

From these theories it emerges that declarative memory is still the subject of controversial studies and appears to be the result of complex constructive and reconstructive mechanisms dependent on extended brain circuits.

The doubt about the reliability of memories arises from the first mnemonic process of information processing. Constructivism argues that knowledge is necessarily dependent on the knowing subject as an active construction process. Objectivity is therefore an illusion: the subject introduces his own order and meaning to what he experiences. The same event is meaning and remembered differently on the basis of one's psycho-physical state (depending on the moment in which it is known), past experiences (which build the representations, defined by the Bowlby theory IWM⁷), and the common sense⁸ determined by the place of belonging and the interactions subsequent to the occurrence of the event. Below we present some theories that analyze the processes that affect the reliability of memories.

The emotion-memory interactions occur in several phases from the construction to recovery of the memory trace by modifying the original data. The amygdala modulates, according to emotions, both the encoding and the memorization of memories dependent on the hippocampus, this in turn generates episodic representations of the emotional meaning and interpretation of events, influencing the response of the amygdala when stimuli are encountered emotional. Although the amygdala and hippocampus are independent, they act in concert (Phelps, 2004): emotions regulate memory and vice versa. The association between mood disorders and memory impairment is due to the fact that dysfunctional emotional alterations reduce the amount of cognitive resources available for the memory domain (Dalgleish & Power, 2004).

⁷ Individuals, through interaction with the environment and in particular with the caregiver, build Internal Working Models from childhood, that is, representations of themselves and the world. These mental structures regulate the perception and interpretation of events, allowing you to make predictions and create expectations about the events of your relational life.

⁸ Pre-conceptual sense, implicitly shared by the members of a cultural context, which allows people to be in tune with what is common (Stanghellini, 2008).

The *Self Memory System*⁹ (Conway & Pleydell-Pearce, 2000) introduces another dynamic influencing memory such as the self-concept. This framework considers memory as a “motivated process” that is guided by the self-goals. Autobiographical knowledge limits what the self is, has been and can be, in turn the self modulates access to long-term knowledge: in the event of changes in the self, memory stores are radically reorganized (Conway, 2005). The self and memory can therefore operate independently and influence each other.

It is also necessary to consider that memories also interact with each other changing them self. This interrelation is called interference, and it is both the tendency of new memories to compromise the recovery of past memories (retroactive) and vice versa the tendency of pre-existing information to influence new events (proactive). As a demonstration of this, it is observed that the mastery of a task can facilitate or hinder the learning or execution of a new task.

At the end of this path, the contribution that Schacter, one of the most famous researcher of memory, has provided to the theme, is exhibited. The scientist argues that memory plays fundamental functions in everyday life, but that it is also vulnerable to error and delusion. He theorized the existence of seven sins (imperfections) by assigning to memory a constructive and adaptive nature (functional to survival). Sins are divided into three types of phenomena: oblivion phenomena (transience, absent-mindedness, blocking), distortion phenomena (misattribution, suggestibility, bias) and pathological phenomena (persistence). Considering the evidence showing the pervasiveness of memory errors, Schacter concludes that memory is a faulty process that has serious repercussions on the legal system, especially in the context of the accuracy of the testimony. In fact, research has shown that post-event suggestion can contaminate a person’s memory by inducing false memories.

This discussion has presented the pitfalls to which the memory is exposed. What emerged has implications not only for police investigations and criminal judgments but also for other disciplinary sectors such as Psychotherapy which has long debated the veracity of memories. The novelty proposed is that Mathematics is trying to combine psychological phenomena with neural correlates explained in terms of mathematical models, to scientifically corroborate what has been observed at a behavioral level.

⁹ The SMS is a paradigm made up of two main components, the working self (complex set of active goals and associated self-images) and the knowledge of autobiographical memory. These components intertwine to form memories and self-representations.

1.2. *The engram: from the biochemical perspective to the mathematical model*

Neuropsychology clarifies the brain psychic and neurophysiological processes regulating memory but does not precisely delineate the activation configurations of neurons in the various mnemonic phases. The innovative connectionist model implements a computational approach of the mind: it attempts to simulate biological intelligence, reproducible on a computer, through artificial neural networks.

Mathematical models can help provide a detailed representation of neural activity during the different memory processes to photograph the neural correlates of coding, consolidation, reconsolidation and recovery of memories. Emerging changing configurations in support of the constructive and reconstructive nature theorized by neuropsychological research.

Below we describe the functioning of the learning process, at the basis of mathematical modelling, starting from the concept of engram. The engram is structured through a biochemical process by which neurons, which once functioned independently, begin to work together as a network. Daniel Hebb was the first, in 1949, to hypothesize that memories are stored in the brain in the form of networks of neurons. Hebb's postulate states that axonic terminations, strengthened thanks to correlated activity, form new branches, while terminations weakened by unrelated activity lose their grip on the post-synaptic cell.

Bills and Lomo, in 1973, discovered that by administering a train of high frequency electrical stimuli (at the hippocampus) the action potentials produced by subsequent stimuli were increased but only in that neural path (the electric current strengthened the synaptic connections along that away for hours or weeks). This is the long-term potentiation (LTP): a persistent increase in synaptic efficacy that mediates the formation of memory. This phenomenon occurs only in the presence of a close temporal correspondence between the paired activities of pre-synaptic and post-synaptic cells.

The neural activity model gradually changes with training to become consistent: the synchrony index of the triggered neurons is low at the beginning but increases with training cycles (Zhou *et al.*, 2020). The change in the dynamics of neurons from irregularity to synchronization coincides with the appearance of learned behaviors (e.g., mouse freezing for fear conditioning). Synaptic plasticity is the generative mechanism of memorization, the LTP with the formation of new synapses regulates the consolidation of memories.

The neuronal dynamics, which determine the memorization, can be described through mathematical models based on measurements of the voltage and time dependence of the currents that cross the membrane. The memorization process is interpreted as a return of the brain to the neuronal configuration equal to the one it had at the time of the stimulus; and the brain network is studied as a mathematical system having dynamic configurations (Luccioli, 2005).

The neuronal network can be represented as a system of N units (neurons) that interact with each other at instant t . At each instant the network is characterized by a configuration determined by the values of the electrical potentials assumed by the neurons. The information is then represented by specific configurations where the first neuron is active and the second quiescent and so on. The potential that the i -th neuron receives from the others is defined by the sum of the potentials that the neurons send to the i -th neuron. A neuron will be active if the sum of the electrical potentials, it receives from the other neurons, exceeds its threshold value in analogy to what happens biologically. On the basis of the mathematically defined configuration it is possible to identify the recognition of a stimulus and compare the configurations at different instants, differentiating the processes of coding and retrieving information (Doria, 1994).

What has been discovered, biologically and mathematically, coded potentially makes it possible to carefully evaluate the admissibility limits of testimonial evidence, the memory impairments in the medical field and the mapping of neural networks as a function of neurosurgical interventions.

2. MATHEMATICAL PERSPECTIVE

The difference in scale between the biological phenomena (neural activities) and the behavioral expressions (mnestic processes) creates room for multiple discipline to be hosted in and, in this scenario, mathematics has taken its role as special guest. The mathematical modelling allows to simulate the association between specific neural configurations and the various cognitive operations laying the foundation for the data neuromorphic processing.

In the current paragraph the most important milestones, success (and perplexities) along the artificial neural networks conceptualization roadmap are presented.

2.1. *The technological keys of the mind*

The difficulties involving a neuromorphic processor realization are multiple. In the classical computational system based on the von Neumann architecture (hardware architecture for programmable digital machines which shares the instructions and the data in the same memory area) the control processing units (CPUs) are physically separated from the memory block, instead in the neural networks, processing and memorization co-exist inside the same synaptic structure. The increase of the completed operations by time unit (i.e. increasing clock frequency), could affect the micro-electronic fabrication process. Considering that forcing the boundaries of the solid state physics is not always a chance some strategical workaround and smart tricks are needed to support the continuous improvement of the computer performance. First of all the multi core parallel computing and the hierarchical organization of cache memory. For the special case of parallelism, Amdahl law state that if F is the fraction of a processing which can be done in parallel, and $(1 - F)$ is the part which has to be done in serial, then the best achievable speedup¹⁰ (S) using a N core machine is:

$$S = \frac{1}{(1 - F) + \frac{F}{N}} \quad (2.1)$$

Looking at the future of computation virtually means to reimage it: the brain organization is one of the most promising and inspiring technological architecture in the roadmap of the computer evolution. The field of application of the neuromorphic computing are wide, as it is extensive the number of solution proposed to reach the final accomplishment.

The new neuromorphic technological platform could be the most natural interface between human body and cybernetic prostheses. This can open a new window on the way to approach the nervous system diseases, as quadriplegia and also more complex clinical picture (Collinger *et al.*, 2013). For the moment this looks like more the (happy) ending of the story. The input processing capacity a biological system can accept (10^4) and the fan-in¹¹, nominal or effective, of the computation machines are order of magnitude different (10^2). Beyond the scale issue it's the *spike-timing* design to be a deep conceptual difference in the information treatment

¹⁰ Computational acceleration of partially divisible algorithm due to the insertion of N processors in parallel.

¹¹ Number of acceptable input from a circuit logic operator.

when compared to the current standard. The *SpiNNaker* project (Spiking Neural Network Architecture) try to jump over the fence by a multi-core architecture based on the paradigm of the brain functioning (Mead, 1990). Its billions of computation units are able to reinforce their interconnection thanks to the STDP mechanism constituting an high parallel degree artificial platform. If compared to the biological systems it is not more than the 1% of the human brain, of if it sounds more encouraging, it is equivalent to ten times a mouse brain (*Fig. 2*).

The basic block of the *SpiNNaker* is the *SpiNNaker multicore System-on-Chip*. The chip is a *Globally Asynchronous Locally Synchronous (GALS) system*¹² where the nodes are represented by 18 *ARM968* processors working in synchronized regime, grafted in a circuitual infrastructure based on the *Address-Event-Representation (AER)*¹³ communication protocol, which allows large fan-in and fan-out. The AER protocol is optimized for the real time housing of a great number of mini-packets able to emulate the neural spikes (Mead, 1990). The strong legacy of the standard management of the computational resources introduced by the classic ARM processors seems to have been further exceeded by the *TrueNorth* project by IBM. The structure is made by 4096 cores which fulfil the role on neural network in turn integrated on a single motherboard. Each one of the core raccoglie 256 simil-neural electronic units (approximately the size of a caterpillar's brain) that allows to program 256×256 binary synaptic connections (Indiveri, 2011).

The True North is the IBM second largest chip ever made and only consumes 73 mW (a thousand time less than a typical commercial CPU) proving, as expected, a natural inclination toward the challenges coming from the domain of the cognitive responses or, from a more computer science point of view, the target themes of the machine learning algorithms (Indiveri & Liu, 2015). A quantitative metric of what just discussed can be better defined looking at the *image recognition* capacity. The TrueNorth is able to categorize 6000 images per watt with respect to a canonical GPU, although excellent, as the NVIDIA Tesla p4 GPU which can perform the identification of just 160 immagini for the same power unit. This approach seems to be most successful than *SpiNNaker* in terms of memory distribution grade (*Fig. 3*).

¹² Computational architecture based on secure and robust communication between synchronous islands in a system of independent clock domains.

¹³ Address Event Representation (AER) is an emerging protocol dedicated to the communication of neuromorphic networks that aims to create a massive interconnection between neural units with a strong real-time focus.

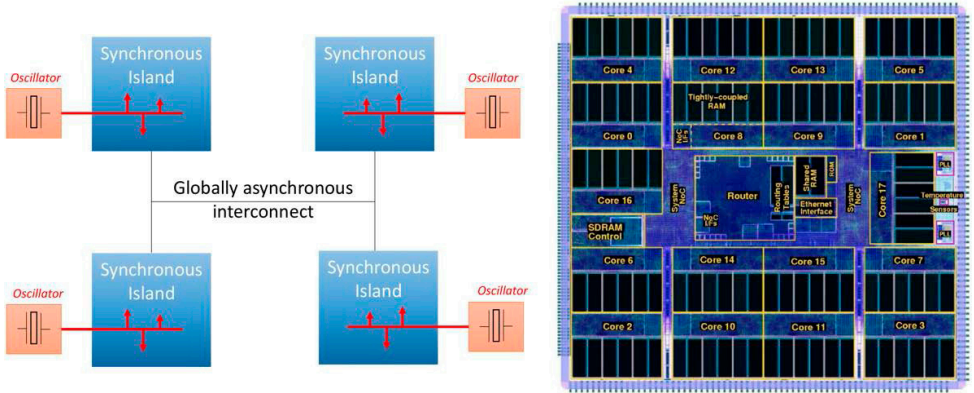

Figure 2. – Schematic representation of the GALs architecture flanked by an image of the SpiNNaker matrix, with the 18 cores (synchronous islands).
 Source: <http://lapt.cs.manchester.ac.uk>.

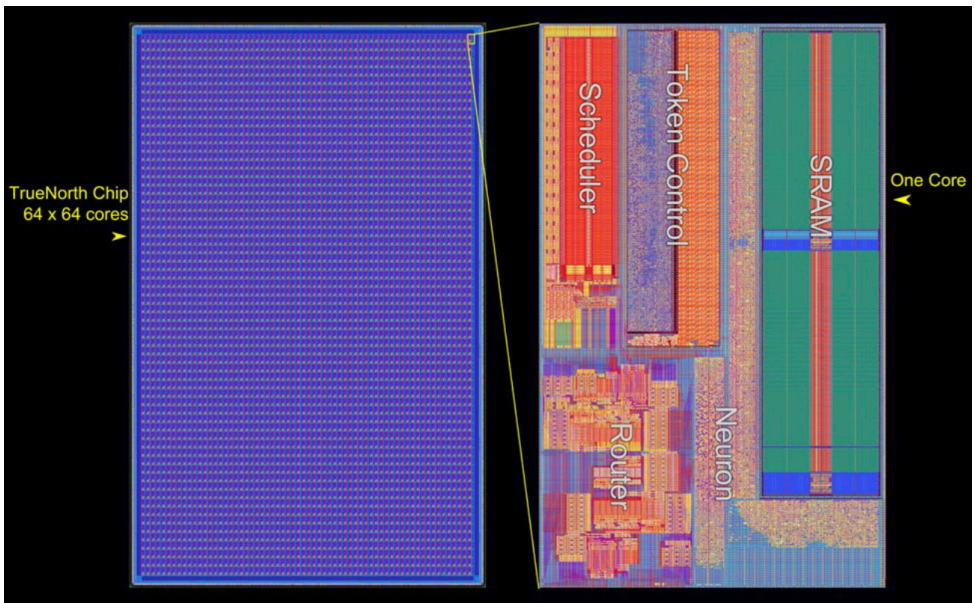

Figure 3. – The Neurogrid Layout (to the left) is characterized by a 64×64 “neurosynaptic cores”. Each core (to the right) owns 256 neurons and 65,536 synapsis.
 Source: IBM Research, CC BY.

One of the main issues is the large size di questo dispositivo, 4.3 cm^2 , which makes questionable is industrial sustainability in term of die yield. Also assuming to miniaturize the chip consistently with the mass production CPU size, the processor shows up a lack of plasticity/learning capacity which represent, instead, a choice taken during the development face in order to simplify design and operation.

As last study case it is proposed the *NeuroGrid* which is based on an unusual array of neurons and synapses made by analog electronic circuits assisted by a digital router. This MixedSignal machine is the apotheosis of the real-time concept thought to handle the data on the fly and avoid any kind of machine state storage (Douglas, Mahowald, & Mead, 1995). It appears to be what is closest to the formlization of coincidence of data retainment with the dynamic dialogue of the circuital components. The network pretends to interact realistically with biological systems and is, therefore, calibrated on time constants of tens of milliseconds. It's a very long time scale if the reference is the digital system performance but for sure, for an analogic VLSI¹⁴ is a very challenging result to reach.

CONCLUSIONS

The studies on memories evolve constantly and the underlying comprehension is gradually becoming more complex and detailed. In particular all the learning about the memories generation and recall mechanism have quicly expanded. An important item in the field is the trustability of the recalled information. The brain is not a passive storage node instead it covers an adaptive function which can cause the memories alteration. This kind of error introduction serves for survival purpose. The memory builds patterns to expedite and facilitate the world understanding, although these processes cause the distortion of remembered events.

The Neuropsychology is helping to clarify the anatomical, physiological and psychic correlates of memory in order to understand its functioning. The Neuropsychological studies show that mental activity is distributed through the brain and not categorized into independent modules: the modularization paradigm has been discarded in favor of the connectionist one, proving the existence of interconnected neural networks.

¹⁴ Very large scale integration (in acronym VLSI) is a denomination that indicates a high integration of transistors within a single chip. Generally it refers to the devices with the highest level of integration based on the technologies of the time.

Mathematics fits into this context by representing complex neural configurations through the mathematical models. All the disciplines offer their contribution in the same direction of establishing the neuromorphic computing theory and design the perfect machine for its interpretation. The development of new IT architectures is slowly becoming a reality. In the 2020 the neural chips market counted 1.952 billion dollars, and it is expected to grow to exceed 7 billion ollars by the 2026 with a particular traction from the automotive market (Mordor Intelligence, 2021).

The integration of psychological, neuro-physiological knowledge with the mathematical one implies making an improvement for different disciplines and for the quality of life of the human being. The General Psychology will be able to answer unresolved questions about the unreliability of memories and their reconstructive nature. The Forensic Neuroscience will have a valid mathematical model that illustrates brain activity during the memorization making the detectives able to easily filter out fake information. Thanks to the Neuroimaging the cerebral images could be directly associated with some computational configuration to support the diagnosis and and the follow-up in in the neurological and psychiatric fields. The Awake Surgery will increase the safety and effectiveness of the interventions throught the systematic mapping by the cerebral network. At the end the Neuropsychological rehabilitation could arrange very precise intervention plan to fix the specific mnesitic impairment and better monitoring the further progresses by the support of the prediction and behaviour suggested by the mathematical modelling.

REFERENCES

- Andrews-Hanna, J. R., Saxe, R., & Yarkoni, T. (2014). Contributions of episodic retrieval and mentalizing to autobiographical thought: Evidence from functional neuroimaging, resting-state connectivity, and fMRI meta-analyses. *Neuroimage*, *91*, 324-335.
- Ardito, R., Pellegrino, S., & Adenzato, M. (2018). Sul rapporto tra reminiscing, memoria episodica eurobiografica e coscienza autoonoetica. Il contributo della teoria dell'attaccamento. *Cognitivismo Clinico*, *15*(2), 101-109.
- Arshavsky, Y. I. (2006). "The seven sins" of the hebbian synapse: Can the hypothesis of synaptic plasticity explain long-term memory consolidation? *Progress in Neurobiology*, *80*(3), 99-113.
- Bartlett, F. C. (1932). *Remembering*. Cambridge University Press.
- Collinger, J. L., Wodlinger, B., Downey, J. E., Wei Wang, W., Tyler-Kabara, E. C., Weber, D. J., McMorland, A. J., Velliste, M., Boninger, M. L., &

- Schwartz, A. B. (2013). High-performance neuroprosthetic control by an individual with tetraplegia. *The Lancet*, 381(9866), 557-564.
- Conway, M. A. (2005). Memory and the self. *Journal of Memory and Language*, 53(4), 594-628.
- Conway, M. A., & Pleydell-Pearce, C. W. (2000). The construction of autobiographical memories in the self-memory system. *Psychological Review*, 107(2), 261-288.
- Dalgleish, Tim, & Power, M. J. (2004). The I of the storm-relations between self and conscious emotion experience: Comment on Lambie and Marcel (2002). *Psychological Review*, 111(3), 812-818.
- Doria, S. (1994). Il processo di memorizzazione descritto mediante il modello neuronale di Hopfield. *Ratio Mathematica*, 8(1), 3-7.
- Douglas, R., Mahowald, M., & Mead, C. (1995). Neuromorphic analogue VLSI. *Annual Review of Neuroscience*, 18, 255-281.
- Dudai, Y. (2012). The restless engram: Consolidations never end. *Annual Review of Neuroscience*, 35, 227-247.
- Eichenbaum, H. (2000). Hippocampus: Mapping or memory? *Current Biology: CB*, 10(21), R785-R787.
- Eustache, F., Viard, A., & Desgranges, B. (2016). The MNESIS model: Memory systems and processes, identity and future thinking. *Neuropsychologia*, 87, 96-109.
- Eysenck, W. M. (2006). *Psicologia generale*. Idelson-Gnocchi.
- Fotopoulou, A., Rudd, A., Holmes, P., & Kopelman, M. (2009). Self-observation reinstates motor awareness in anosognosia for hemiplegia. *Neuropsychologia*, 47(5), 1256-1260.
- Harley, K., & Reese, E. (1999). Origins of autobiographical memory. *Developmental Psychology*, 35(5), 1338-1348.
- Indiveri, G., & Horiuchi, T. (2011). Frontiers in neuromorphic engineering. *Frontiers in Neuroscience*, 5(118), 1-2.
- Indiveri, G., & Liu, S.-C. (2015). Memory and information processing in neuromorphic systems. *Proceedings of the IEEE*, 10(10).
- Kuyken, W., & Dalgleish, T. (2011). Overgeneral autobiographical memory in adolescents at risk for depression. *Memory (Hove, England)*, 19(3), 241-250.
- Luccioli, S. (2005). *Dinamica di modelli realistici di singolo neurone*. Tesi di laurea in Fisica, Università degli Studi di Firenze.
- Mead, C. (1990). Neuromorphic electronic systems. *Proceedings of the IEEE*, 78(10), 1629-1636.
- Newcombe, N. S., Lloyd, M. E., & Ratliff, K. R. (2007). Development of episodic and autobiographical memory: A cognitive neuroscience perspective. *Advances in Child Development and Behavior*, 35, 37-85.

- Perner, J., & Ruffman, T. (1995). Episodic memory and auto-noetic consciousness: Developmental evidence and a theory of childhood amnesia. *Journal of Experimental Child Psychology*, 59(3), 516-548.
- Phelps, E. A. (2004). Human emotion and memory: Interactions of the amygdala and hippocampal complex. *Current Opinion In Neurobiology*, 14(2), 198-202.
- Purves, D., Augustine, G. J., Fitzpatrick, D., Hall, W. C., Lamantia, A.-S., & White, L. E. (2013). *Neuroscienze*. Zanichelli.
- Purves, D., Cabeza, R., Huettel, S. A., Labar, K. S., Platt, M. L., & Woldorff, M. G. (2015). *Neuroscienze cognitive*. Zanichelli.
- Schacter, D. L. (2013). Memory: Sins and virtues. *Annals of the New York Academy of Sciences*, 1303(1), 56-60.
- Schacter, D. L., & Addis, D. R. (2007). The cognitive neuroscience of constructive memory: Remembering the past and imagining the future. *Philosophical Transactions of the Royal Society of London. Series B, Biological Sciences*, 362(1481), 773-786.
- Schacter, D. L., Guerin, S. A., & St. Jacques, P. L. (2011). Memory distortion: An adaptive perspective. *Trends in Cognitive Sciences*, 15(10), 467-474.
- Schedlbauer, A. M., Copara, M. S., Watrous, A. J., & Ekstrom, A. D. (2014). Multiple interacting brain areas underlie successful spatiotemporal memory retrieval in humans. *Scientific Reports*, 4(1), 1-9.
- Siegel, D. J. (2012). *The developing mind: How relationships and the brain interact to shape who we are*. Guilford Press.
- Squire, L. R., Genzel L., Wixted J. T., & Morris R. G. (2015). Memory consolidation. *Cold Spring Harb Perspect Biol.*, 7: a021766. doi: 10.1101/cshperspect.a021766
- Stanghellini, G. (2008). *Psicopatologia del senso comune*. Raffaello Cortina Editore.
- Vaccaro, P. (2017). *Connessionismo e PDP. L'elaborazione distribuita parallela come modello della mente*. Tesi di laurea in Filosofia, Università degli Studi di Firenze.
- Vallar, G., & Papagno, C. (2011). *Manuale di neuropsicologia*. Il Mulino.
- Wagner, A. D., Stebbins, G. T., Masciari, F., Fleischman, D. A., & Gabrieli, J. D. (1998). Neuropsychological dissociation between recognition familiarity and perceptual priming in visual long-term memory. *Cortex: A Journal Devoted to the Study of the Nervous System and Behavior*, 34(4), 493-511.
- Young, A. R., Dean, M. E., Plank, J. S., & Rose, G. S. (2019). A review of spiking neuromorphic hardware communication systems. *IEEE Access*, 7, 135606-135620. doi: 10.1109/ACCESS.2019.2941772
- Zhou, Y., Qiu, L., Wang, H., & Chen, X. (2020). Induction of activity synchronization among primed hippocampal neurons out of random dynamics is key for trace memory formation and retrieval. *FASEB Journal: Official Publication of the Federation of American Societies for Experimental Biology*, 34(3), 3658-3676.

RIASSUNTO

La comprensione della memoria si configura, da secoli, come una sfida costante per la ricerca scientifica. I processi mnestici, determinanti l'identità dell'essere umano, sono stati indagati attraverso molteplici punti di vista, come quello psicologico, neurofisiologico e fisico. Ne risultano visioni complesse e sfaccettate che andrebbero integrate per fornire un'interpretazione unitaria e completa. Si effettua una ricognizione della letteratura scientifica più recente, sul funzionamento della memoria dichiarativa, per analizzare la relazione tra l'informazione reale proveniente dal mondo esterno, l'evento codificato e il ricordo recuperato. L'obiettivo del saggio è indagare i correlati neurali, che regolano il sistema cognitivo in oggetto, mediante una duplice interpretazione neuropsicologico-matematica. La Neuropsicologia fa luce sui meccanismi anatomici, fisiologici e psichici della memoria mentre la Matematica associa alle reti neurali le corrispondenti configurazioni matematiche. Il percorso di ricongiungimento, tra le due discipline, si realizza attraverso la simulazione computazionale neuromorfica che emula il "mind uploading".

Copyright (©) 2021 Federica Doronzo, Gianvito Calabrese

Editorial format and graphical layout: copyright (©) LED Edizioni Universitarie



This work is licensed under a Creative Commons

Attribution-NonCommercial-NoDerivatives 4.0 International License.

How to cite this paper:

Doronzo, F., & Calabrese, G. (2021). Functioning of declarative memory: Intersection between neuropsychology and mathematics. *Elementa. Intersections between Philosophy, Epistemology and Empirical Perspectives*, 1(1-2), 163-179. DOI: <https://dx.doi.org/10.7358/elem-2021-0102-doca>