

## NUMERICAL CALCULATIONS OF ADHESIVE JOINTS SUBJECTED TO SHEARING

JAN GODZIMIRSKI  
SŁAWOMIR TKACZUK

*Military University of Technology, Warsaw*

*e-mail: Jan.Godzimirski@wat.edu.pl; Slawomir.Tkaczuk@wat.edu.pl*

The paper proposes a method for determination of mechanical properties of adhesive layers (necessary for numerical calculations) by means of samples from a glue cast subjected to compression as well as a method of taking adhesion into account in numerical calculations of adhesive bonds. Additionally, a method of numerical modelling of adhesive bonds subjected to shearing was proposed. It was proved that, due to the actual shape of the adhesive layer edge, it can be modelled by one layer of finite elements in numerical calculations.

*Key words:* adhesive bonds, shearing, numerical calculations

### 1. Introduction

The structural gluing is one of the methods of fast integration of parts of machines, installations, vehicles and aircrafts. A properly designed glued joint should be subjected mainly to shearing. So far, there are no credible methods of calculating the strength of glued joints. This lack applies even to the static strength of joints subjected to shearing (Godzimirski, 1998). The reason for this is the complex state of stresses in adhesive layers of most glued joints (Godzimirski, 2002), non-linear  $\sigma = \sigma(\varepsilon)$  relation of adhesives (Biedunkiewicz and Majda, 2004) and the possibility of both: cohesive and adhesive wear of an adhesive layer. Cohesion is a state in which particles of a single substance are held together by primary or secondary valence forces observed in the tendency of the substance to stick to itself. Adhesion is a power of an adhesive layer to hold the parts of an assembly together. Two surfaces are held together by interfacial forces which may consist of valence forces or interlocking action. A reliable prediction of the static strength of

glued joints is not possible without numerical calculations (Godzimirski and Tkaczuk, 1998; Gutkowski *et al.*, 1996). However, the application of numerical methods requires knowledge of mechanical properties of the materials which constitute the joint under examination. Among others, one has to take into account the  $\sigma = \sigma(\varepsilon)$  relation of the adhesive with the full range of its possible strains as well as adopt a correct numerical model of the glued joint.

Determination of the  $\sigma = \sigma(\varepsilon)$  relation of an adhesive rises controversy relating to the possibility of determining such adhesive layer properties using cast samples or samples cut out of a cured block of the adhesive. Dimensions of adhesive layers (thickness  $\sim 0.1$  mm) cause problems in the attempts to determine even the initial parts (ELEMENTS) of their  $\sigma = \sigma(\varepsilon)$  characteristics. Described trials to experimentally determine Young's modulus of adhesive layers (Czarnomska, 1987; Świtkiewicz, 1978) seem to carry implausible errors because of the research methods used. Moreover, established values lack positive verification by strength calculations. The authors' own tests (Godzimirski, 1982) as well as those presented in Biedunkiewicz and Majda (2004) prove that mechanical properties of adhesive layers determined by the  $\sigma = \sigma(\varepsilon)$  relation are comparable to those made from cured adhesive samples, thus making it possible to determine mechanical properties of adhesive layers using samples from the adhesive cast. The experimental determination of the  $\sigma = \sigma(\varepsilon)$  characteristic curve by means of such samples presents no technical problem. A preparation of oar shaped samples is relatively simple. Also the measurements of their strains are more accurate than the measurements of adhesive layers strains. However, tension curves of the oar shaped samples usually do not allow one to determine the full range of the  $\sigma = \sigma(\varepsilon)$  characteristic of the adhesive layer. Neither do they allow one to determine the value of breaking stresses which in adhesive layers are usually greater than static strength of cast samples. For example, the breaking stresses of Epidian 57 adhesive layer reach values in the range of 75 MPa (Godzimirski and Tkaczuk, 2002). Additionally, samples made from adhesive allow one to determine only cohesion properties of the adhesive.

Therefore the problem of numerical calculation of adhesive bonds requires:

- to work out a method for determination of mechanic properties of adhesive layers in the full range of their strains,
- to use a correct numerical model of the joint,
- to take into account in numerical calculations the adhesion properties of the adhesive layer.

In this paper, the solution for the above mentioned problems are presented.

## 2. Determination of mechanical properties of the adhesive

Experimental tests designed to determine the  $\sigma = \sigma(\varepsilon)$  characteristic curve of an adhesive conducted using the oar shaped samples subjected to tension do not provide satisfactory results. Out of the series of samples tested, only few obtained high strain values. Therefore, it was decided to verify the usability of different samples for the determination of mechanical properties of adhesives. The compressed, cylindrical samples were tested.

The dimensions of cylindrical samples made of Epidian 57 and Araldite AW136H and used in the experiment are shown in Tables 1 and 2. These samples were subjected to axial-symmetrical compression in the ZD-10 testing machine, and the values of forces in function of strains were recorded. On the basis of this test, graphs of the  $\sigma = \sigma(\varepsilon)$  function were made (Fig. 1 and Fig. 2).

**Table 1.** Measurements of cylindrical samples made of Epidian 57

ID sample	1	2	3	4	5	6	7	8
length $l$ [mm]	20.80	21.22	27.76	21.80	16.88	19.66	20.96	22.26
diameter $\Phi$ [mm]	12.50	12.54	12.16	12.30	11.92	11.58	11.74	11.95

**Table 2.** Measurements of cylindrical samples made of Araldite AW136H

ID sample	1	2	3	4	5	6	7
length $l$ [mm]	29.32	21.28	28.80	23.90	25.00	24.20	19.60
diameter $\Phi$ [mm]	21.00	12.54	12.50	12.50	12.50	12.50	12.50

Regardless of the length-to-diameter ratio ( $l/d$ ) of the sample, the compression curves of the cylindrical samples had similar shapes. Considerable repeatability of the experimental results was noted. Comparison of the averaged tension and compression curves of the Araldite adhesive obtained in the tests of at least 6 samples are shown in Fig. 3.

The carried out tests demonstrated very important characteristic of the cylindrical compressed samples, namely that it is possible to get maximum ( $\varepsilon$ ) strains with the value of  $\langle 0.07, 0.1 \rangle$  and corresponding maximum stresses of 70-80 MPa. The oar shaped samples subjected to tension did not allow for such a range of strains and stresses. Numerical calculations were conducted in order

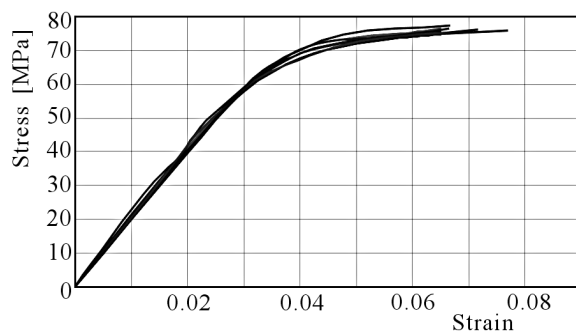

Fig. 1. Compression curves for Epidian 57

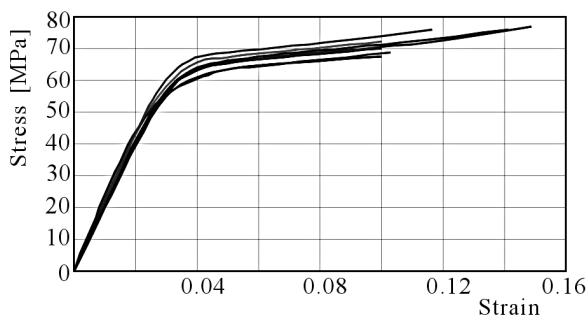

Fig. 2. Compression curves for Araldite AW 136H

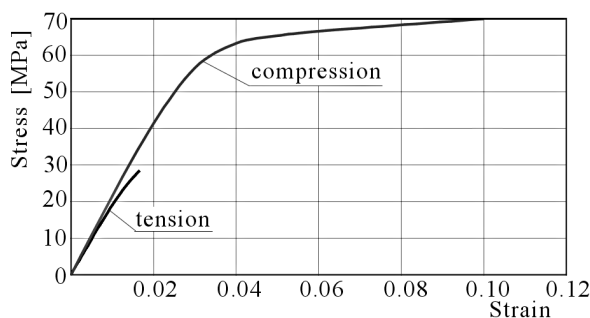

Fig. 3. Comparison of tension and compression curves of the Araldite AW 136H adhesive

to estimate the grade of roughness stresses distribution in compressed samples which resulted from the impact of the testing machine handles (disks). The sample was simulated with solid figure elements in the Nastran for Windows. The calculations were made for different slenderness ratio ( $l/d$ ) of the samples. The numerically tested samples were subjected to displacement determined in the experimental tests. The adhesive was treated as a material with properties described by the  $\sigma = \sigma(\varepsilon)$  function.

It has been concluded that, except for the layers which came into contact with the testing machine handles, the stresses distribution is rather uniform but it depends on the  $l/d$  ratio. Based on the numerical results, it has been concluded that the cylindrical samples (where  $l/d = 2$ ) can be used for determination of the  $\sigma = \sigma(\varepsilon)$  characteristic of adhesives. At this point, such samples are not subject to buckling during the experimental test and they are characterized by a sufficiently uniform distribution of stresses.

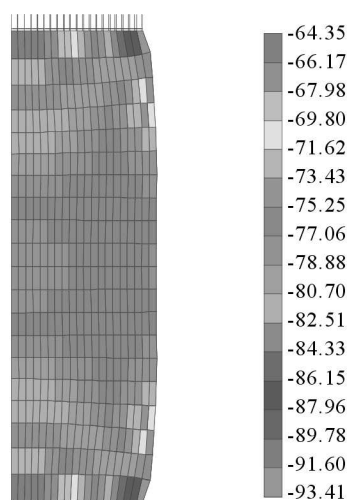

Fig. 4. Exemplary distribution of maximum principal stresses along sections of cylindrical sample (where  $l/d = 1.77$ )

### 3. Selection of numerical models of adhesive joints subjected to shearing

Based on the numerical calculations and experimental tests of adhesive bonds subjected to shearing it has been concluded that calculated values of the level of stresses are greater than those determined for different types of glued joints and for stresses determined in cylindrical samples compression tests. It was assumed that one of the reasons for this discrepancy may be an improper modelling of adhesive layers of joints subjected to shearing. The numerical calculations were made to verify whether the calculated stress value in the adhesive layer is dependent on the density of the elements net (the size of elements which model the adhesive layer) and whether the models of the adhesive layer used allow for convergent solution.

The numerical tests were conducted for a glued single lap joint according to the PN-69/C-98300 measurement standards (Fig. 5).

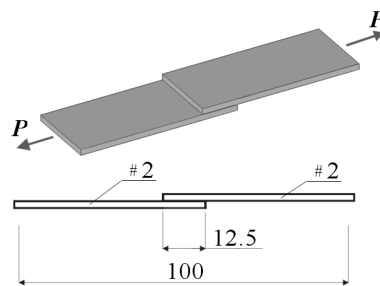

Fig. 5. A single lap sample according to standard PN-69/C-98300

The sample was modelled as made of PA7T4 aluminium alloy glued with the Araldite AW136 with HY996 hardener. The value of creeping load was 7000 N. This value was confirmed by experimental tests. The measurements of the tested joint are shown in Table 3.

**Table 3.** Geometric data of the single lap model

Thickness of adhesive layer [mm]	Adhered thickness [mm]	Single lap length [mm]	Width of sample [mm]	Length of lap [mm]
0.1	2	100	25	12.5

Mechanical properties of the adhesive, declared in the calculations, were determined based on the compression curve ( $\sigma = \sigma(\varepsilon)$ ) of the Araldite adhesive which was experimentally set with cylindrical samples (Fig. 3). Because of its regular shape and the manner of loading, the single lap sample was modelled by plate rectangular elements. The adhesive layer was modelled by 3 or 6 layers of finite elements. The geometrical dimensions of the adhesive layer elements were being changed in order to achieve a larger density of its net. Four three-layer net models and four six-layer ones were created. The geometrical dimensions of the elements of numerical models are shown in Table 4.

The numerical record of the width and height of the elements was included in their markings. The height of the elements was 0.033 mm in the three-layer adhesive layer model and 0.0166 mm in the six-layer one. The maximum principal stress values in the most loaded element of the adhesive layer depending on the elements dimensions is presented in Fig. 6.

**Table 4.** Geometrical dimensions of quadrangular (rectangular) elements used for the adhesive layer modelling

Number of element layers of adhesive	Name of element	Geometrical dimensions of the element	
		width $b$ [mm]	height $h$ [mm]
3 layers	05 × 033	0.05	0.033
	025 × 033	0.025	0.033
	0125 × 033	0.0125	0.033
	00625 × 033	0.00625	0.033
6 layers	05 × 0166	0.05	0.0166
	025 × 0166	0.025	0.0166
	0125 × 0166	0.0125	0.0166
	00625 × 0166	0.00625	0.0166

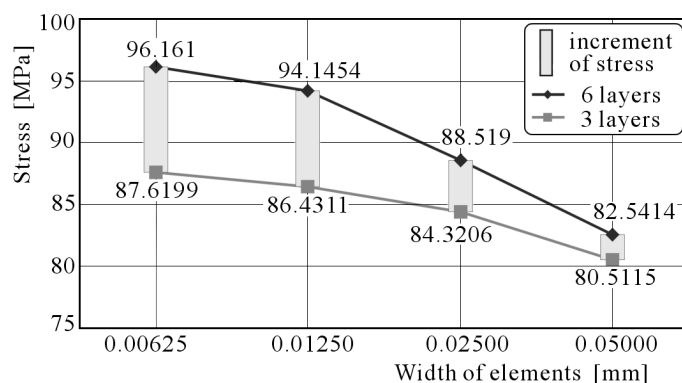

Fig. 6. The maximum principal stress in the most loaded element of the adhesive layer depending on elements dimensions

A continuous increase of stresses along with the reduction of the elements dimensions was found in both the tree-layer and the six-layer models of the adhesive. In search for such a method of adhesive layer modelling which would allow one to obtain convergent results of numerical calculations, an essential property of the adhesive bonds was taken into account. Namely, the edge of the adhesive layer is not perpendicular to the adherent surface even after careful removal of the adhesive "flash". Therefore, comparative investigations were carried out. During them, a different geometry of the adhesive layer edge was considered. This geometry results from the existence of a small (equal in dimension to the thickness of the adhesive layer) adhesive flash which occurs on the boundary between the adhesive layer and adherents. The numerical calculations were made for two model versions of the adhesive layers with "flash" (Fig. 7).

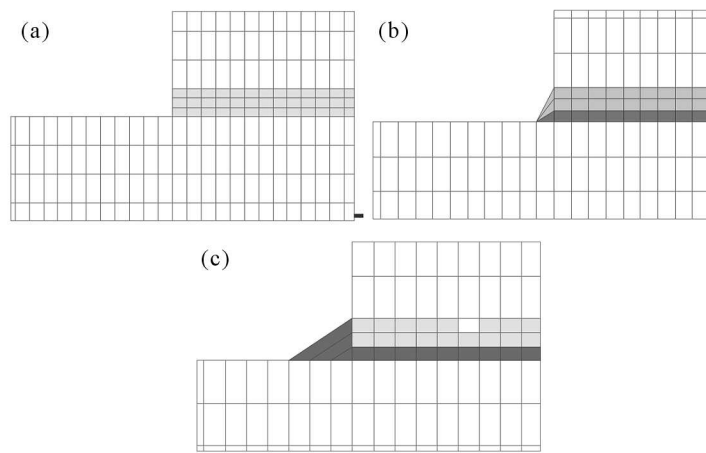

Fig. 7. Modelling versions of the tree-layer adhesive layer edges with simple single lap bonds: (a) traditional (without "flash"), (b) 1st version, (c) 2nd version (with "flash")

Exemplary results of the numerical calculations made for the adhesive layer modelled according to the 1st version are shown in Fig. 8.

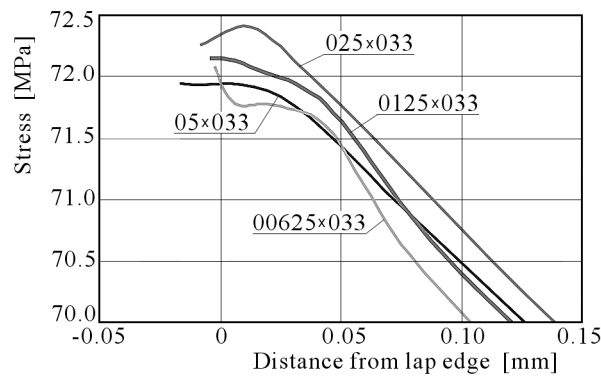

Fig. 8. Distribution of the maximum principal stresses along the utmost section of the lower adhesive layer for the 1st version of the "flash" modelling (adhesive layer modelled by 3 element layers)

Based on the analysis of numerical results, it has been concluded that the modelling of the adhesive layer "flash", especially according to the 1st version, caused the lack of considerable increase of stresses in the utmost elements of the adhesive layers along with the thickening of the elements net. It was also found that taking into account the adhesive "flash" in the adhesive layer model has significant effect on the stress distribution in the adhesive layer and causes uniformity of the stress distribution in all layers of the adhesive layer elements (Fig. 9). This allows one to model the adhesive layer by one layer of elements.



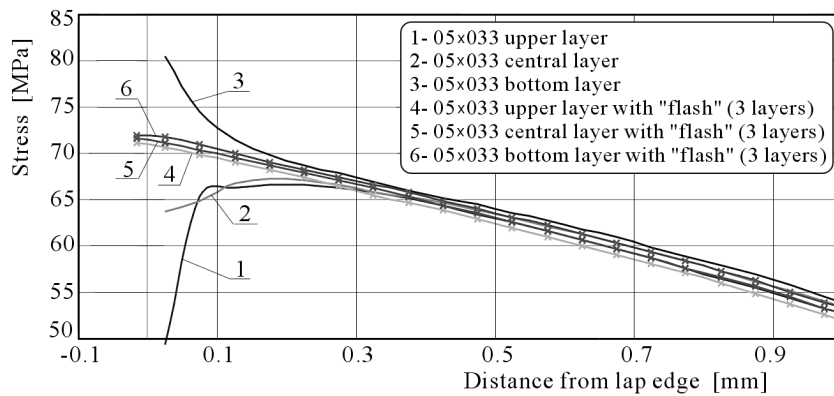

Fig. 9. Comparison of the maximum principal stress distribution along adhesive layer length modelled by three layers of elements both with and without "flash"

The numerical investigations conducted led to following conclusions:

- small (equal in dimension to the thickness of the adhesive layer) "flashes" which are present at the edges of the adhesive layers of the glue joint subjected to shearing cause considerable reduction of stress concentrations in the adhesive layers as well as uniformity of stresses along the thickness of the adhesive layer,
- the uniformity of stresses along the thickness of the adhesive layer allows one to model the adhesive layer with one element layer, thus simplifying in great extent the numerical modelling of the glue joint,
- taking into account in numerical models the presence of "flashes" at the edge of adhesive layers decreases the stress level in this layer down to the value of adhesive crippling stresses determined by cylindrical compressed samples.

#### 4. Numerical modelling of adhesion in adhesive bonds

According to the adopted hypothesis, the adhesive strength of adhesive bonds is connected with their tension strength. So the adhesive strength can be determined experimentally using frontally glued samples subjected to axial-symmetrical tension. If the value of adhesive forces (normal stresses) determined in such a way is smaller than the static strength of the adhesive (cohesion strength), then the glue joint may yield to adhesion failure. It will directly occur when the normal positive stresses, perpendicular to the glued surface, in adherent to this surface adhesive layer, exceed the value of

experimentally determined adhesion stresses. Therefore, in numerical calculations, it is necessary to check not only the effort of the adhesive layer according to a specific effort hypothesis for determination of adhesive cohesion effort (hypothesis of the maximal stress seems to be right for the assessment of adhesive layer effort (Godzimirski, 1985; Kubissa, 1982)) but the value of normal positive stresses perpendicular to the glued surface as well.

It was decided to verify the adopted hypothesis by conducting an experimental test and numerical calculations.

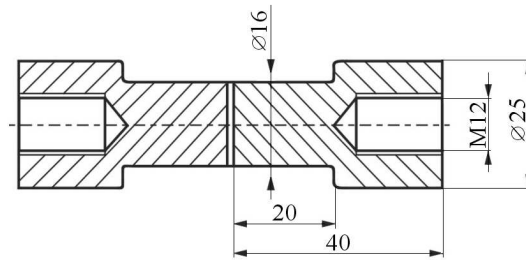

Fig. 10. Frontally glued cylindrical sample (simple butt joint) applied for testing of the adhesive tension strength

Shown in Fig. 10 frontal glued cylindrical samples were applied to testing of the adhesive tension strength. Such samples, fixed articulationally in the testing machine handles ensure axial-symmetrical loading of the adhesive layer more effectively than those recommended by the PN-65/C-89301 standard. Shown in Fig. 11 samples were used for determination of the strength of various adhesive bonds necessary for conducting numerical calculations.

Adhesive Epidian 57 cured for 1 hour at temperature  $60^{\circ}\text{C}$  with  $Z - 1$  and adhesive Araldite AW136 cured for 1 hour at temperature  $100^{\circ}\text{C}$  with HY994 were used in tests. Glued surfaces of all samples used in the tests were prepared for gluing by roughening with a No. 300 abrasive paper and washing with extraction naphtha (samples glued with Epidian 57) or acetone (those glued with Araldite AW136). Such a poorly effective manner of surface preparation followed from the necessity to obtain a small value of the adhesion strength. In the strength tests, six samples were prepared for every measuring point. The test results were elaborated statically: Student-Fisher's method was applied to calculate the confidence interval for the level  $\alpha = 0.95$ . The results of strength tests for the given samples are shown in Table 5.

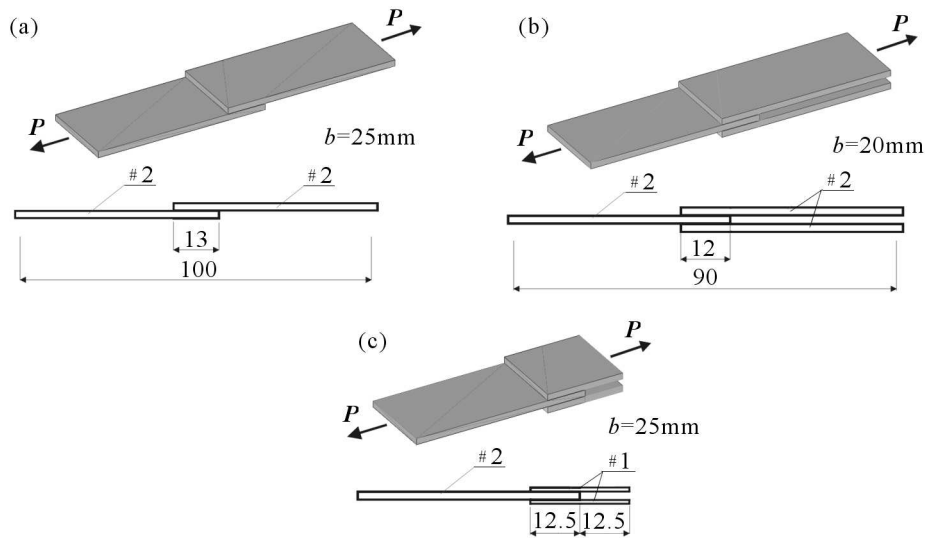

Fig. 11. Samples used for determination of the strength of various adhesive bonds: (a) single lap, (b), (c) double lap ( $b$  – width of samples)

**Table 5.** Strength results of the tested samples

Type of sample	Type of adhesive	Method of application load	Strength [N]
Fig. 10	Epidian 57	tension	$6651 \pm 873$
Fig. 11c	Epidian 57	tension	$15912 \pm 277$
Fig. 11a	Epidian 57	tension	$3549 \pm 412$
Fig. 11a	Epidian 57	bending $l = 36\text{ mm}$	$608 \pm 39$
Fig. 10	Araldit AW 136	tension	$9467 \pm 503$
Fig. 11a	Araldit AW 136	tension	$5812 \pm 569$
Fig. 11b	Araldit AW 136	tension	$12925 \pm 1955$

Based on the tests conducted, the value of normal stresses were calculated for adhesive layers of the cylindrical samples frontally glued (arithmetic means of the sample strengths were divided by the area of the adhesive layer). It was assumed that those were the values of the adhesion strength of tested adhesives and that they were valid for the method used to prepare the glued surface. The values of these strengths were as follows:

- $\sigma_a = 33.26 \pm 4.37\text{ MPa}$  for Epidian 57 adhesive
- $\sigma_a = 47.332.52\text{ MPa}$  for Araldite 136AW adhesive

NASTRAN for Windows programme was used for numerical calculations. The actual thickness of samples sheets, overlaps lengths, thickness of the adhesive

layers obtained and the spacing of the testing machine handles were measured. These data were used in the numerical calculations. The computational numerical models were formulated on the basis of actual dimensions of the tested samples. The calculations were conducted for non-linear adhesive characteristics. The  $\sigma = \sigma(\varepsilon)$  characteristic curves of the adhesive layers were adopted based on the set of compression curves (Fig. 1 and Fig. 2). The tested models of samples were loaded with average forces according to experimental tests in respective groups. The stretched single lap samples were extra loaded with a displacement resulting from the fact that they were clamped in rigid holders of the testing machine. The calculation of bending of the single lap sample was conducted for two support models: in the first model one bearing was fixed while the second one was slidable, in the second model both bearings were fixed (Fig. 12).

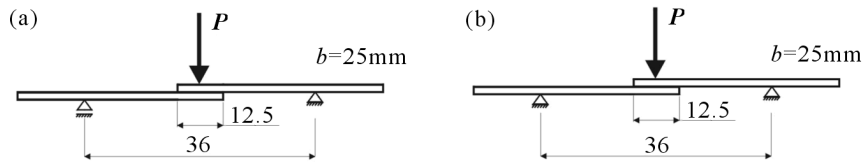

Fig. 12. Support models of the single lap samples loaded with bending: (a) one bearing slidable, (b) both bearings fixed; ( $b$  – width of the samples)

After the calculations, the maximum principal stress values in adhesive layers of the tested models and the maximum normal stress values perpendicular to the glued surfaces adherent to them were recorded. These values are shown in Table 6 and are compared with experimentally found adhesion strengths.

**Table 6.** Comparison of the maximum stresses in adhesive layers of tested models with experimentally found adhesion strengths

Type of adhesive	Adhesion strength [MPa]	Type of sample	Maximal principal stress [MPa]	$\mathcal{A}$
Epidian 57	$33.26 \pm 4.37$	Fig. 11c (T)*	70.86	$33.59 \pm 0.6$
		Fig. 11c (T)*	$68.09 \pm 7.8$	$36.56 \pm 4.2$
		Fig. 11b (B)* I w.	$70.81 \pm 4.0$	$44.10 \pm 2.5$
		Fig. 11b (B)* II w.	$35.30 \pm 2.0$	$23.21 \pm 1.3$
Araldit AW136	$47.33 \pm 2.52$	Fig. 11a (T)*	$71.12 \pm 10.8$	$52.36 \pm 7.9$
		Fig. 11b (T)*	$67.79 \pm 3.6$	$43.18 \pm 2.3$

$\mathcal{A}$  – Maximal normal stress perpendicular to glued surfaces [MPa]

\*(T) – tension samples; (B) – bend samples

Considering the confidence intervals of the experimentally obtained results, it can be concluded that numerically calculated, maximum normal stresses perpendicular to the glued surfaces, did not exceed in the overlap stretched samples the adhesion strength values, which were assumed to be equal to the tension strength of frontal adhesive layers. Calculated for the overlapped samples under bending, these stresses differed considerably from the assumed adhesion strengths. This resulted from the fact that – because of the support method – none of the computational models properly map the actual strength test conditions. The actual conditions of the experiment were intermediate between those adopted in calculations. Therefore, the calculated stress value was too big for the first version of calculation and too small for the second one. Therefore, single lap samples under bending can be subject to comparison tests, but not used for determination of the value of breaking stress of the adhesive layer. It seems that the proposed method of taking into account the adhesive layer adhesion properties may be used in numerical strength calculations of adhesive bonds.

## 5. Summary

Due to the complex state of stresses in adhesive layers, the Finite Element Method (FEM) is useful for calculations of the adhesive bonds strength.

The level of stresses and strains in thin adhesive layers are comparable with the level of stresses and strains obtained in compressed samples which have greater dimensions and volume.

It seems that the proposed method of determining mechanical properties of adhesives and the proposition of taking into account the adhesion forces may be useful in numerical calculations of adhesive bonds and should enable prediction of the adhesive joints strength by (FEM).

The use of the Finite Element Method does not always allow one to precisely model the actual load conditions of calculated elements or joints. Numerically analysed adhesive bonds are very "sensitive" to accuracy of their mapping by means of a computational model.

## References

1. BIEDUNKIEWICZ W., MAJDA P., 2004, A model of an adhesive joint subjected to shearing, *Postępy Technologii Maszyn*, **28**, 1, 23-36

2. CZARNOMSKA M., 1987, Wpływ starzenia na nośność metalowych połączeń klejonych, Rozprawa doktorska, Politechnika Warszawska
3. GODZIMIRSKI J., 1982, Ocena przydatności znormalizowanych prób do określania właściwości wytrzymałościowych klejów do metali, Rozprawa doktorska, WAT
4. GODZIMIRSKI J., 1985, Określanie naprężeń w spoinach klejowych metodą elementów skończonych, *Biuletyn WAT*, **399**, 11, 77-81
5. GODZIMIRSKI J., 1998, Prognozowanie wytrzymałości doraźnej połączeń klejowych, *Postępy Technologii Maszyn i Urządzeń*, **22**, 3, 5-24
6. GODZIMIRSKI J., 2002, *Wytrzymałość doraźna konstrukcyjnych połączeń klejowych*, WNT, Warszawa
7. GODZIMIRSKI J., TKACZUK S., 1998, Ocena przydatności metod numerycznych do obliczania wytrzymałości doraźnej połączeń klejowych, *Biuletyn WAT*, **553**, 9, 111-120
8. GODZIMIRSKI J., TKACZUK S., 2002, Wyznaczanie modułu Younga klejów konstrukcyjnych, *Biuletyn WAT*, **600**, 8, 159-166
9. GUTKOWSKI R.M., CONRAD J., PELIKANE P.J., 1996, Formulation of a bondline element of modeling glued joints in wood, *Mechanika Teoretyczna i Stosowana*, **34**, 1, 101-128
10. KUBISSA J., 1982, Problemy wyznaczania nośności klejonych połączeń metali, *Inżynieria i Budownictwo*, **453/454**, 8/9, 169-171
11. ŚWITKIEWICZ R., 1978, Klejenie w konstrukcjach lotniczych, *Technika Lotnicza i Astronautyczna*, **11**, 11-14

### Numeryczne obliczanie połączeń klejowych obciążonych na ścinanie

#### Streszczenie

W pracy zaproponowano metodę wyznaczania właściwości mechanicznych spoin klejowych potrzebnych do obliczeń numerycznych za pomocą próbek odlewanych z kleju poddawanych ścisaniu oraz sposób uwzględniania adhezji w obliczeniach numerycznych połączeń klejowych. Ponadto zaproponowano sposób modelowania numerycznego spoin połączeń obciążonych na ścinanie i wykazano, że ze względu na rzeczywisty kształt ich krawędzi w obliczeniach numerycznych można modelować spoinę jedną warstwą elementów skończonych.

*Manuscript received July 18, 2006; accepted for print December 1, 2006*